

Raised Veggie Bed

YellaWood
Pressure Treated Pine

This plan is so simple you could build several of various sizes in one day. The simple corner trim detail serves to both cover the end grain of the side pieces as well as reinforcing the corners. Landscape fabric stapled to the bottom keeps your potting mix in place while allowing adequate drainage for your plantings.

Perfect for a patio or deck, you can tend a little patch of vegetables just outside your door. You can also grow herbs or flowers, or you can place them around your home to use as landscape beds. The concepts and details are the same; the only thing you have to change is the measurements of your side pieces.

BUILD TIME

Cutting parts: Less than 1 hour

Assembly: Less than 1 hour

Finishing: 1 hour

Total: 2 – 3 hours

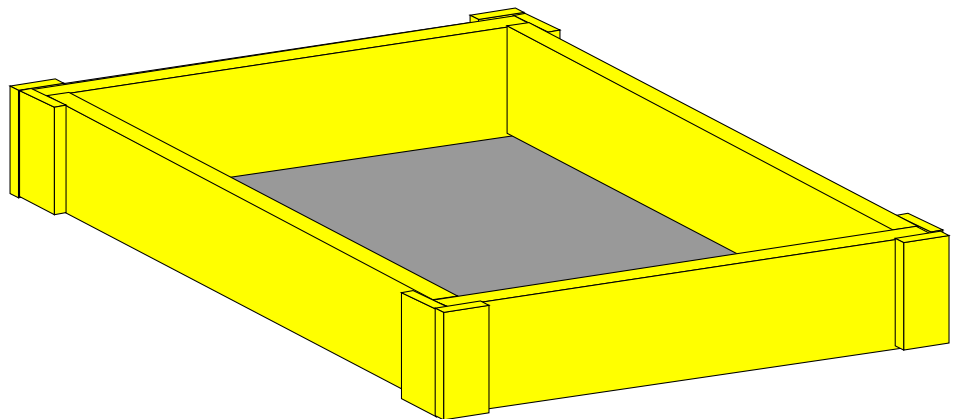

Raised Veggie Bed

YellaWood
Pressure Treated Pine

TOOLS

Circular saw or miter saw (or even a hand saw)
Drill/driver
7/64" drill bit
Hammer
Utility knife
Brad nailer or hammer and nail set
Paint/Stain Brush

SUPPLIES

(1) 2 x 8 x 8'
(1) 1 x 4 x 5'
3" deck screws
1 1/2" galvanized brads or finish nails
3/8" galvanized staples
Landscape fabric (at least 24"x 27")
YellaWood Protector® Stain & Sealer

CUT LIST

A	(4)	1 1/2" x 7 1/4" x 24"
B	(8)	3/4" x 3 1/2" x 7 1/4"
C	(1)	trim to fit

A

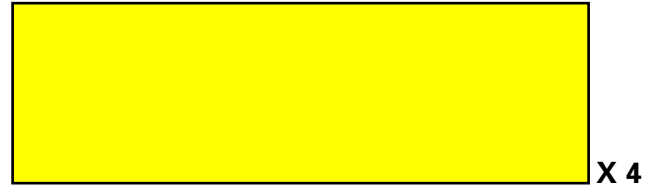

B



C



****Note**** We did not show the use of weatherproof glue in this assembly, as an eventual weathered, curled look with somewhat loose joints is preferred in this case. By all means, however, the use of glue and a quality finish is recommended if that "weathered barn" look is not what you eventually want..

Raised Veggie Bed

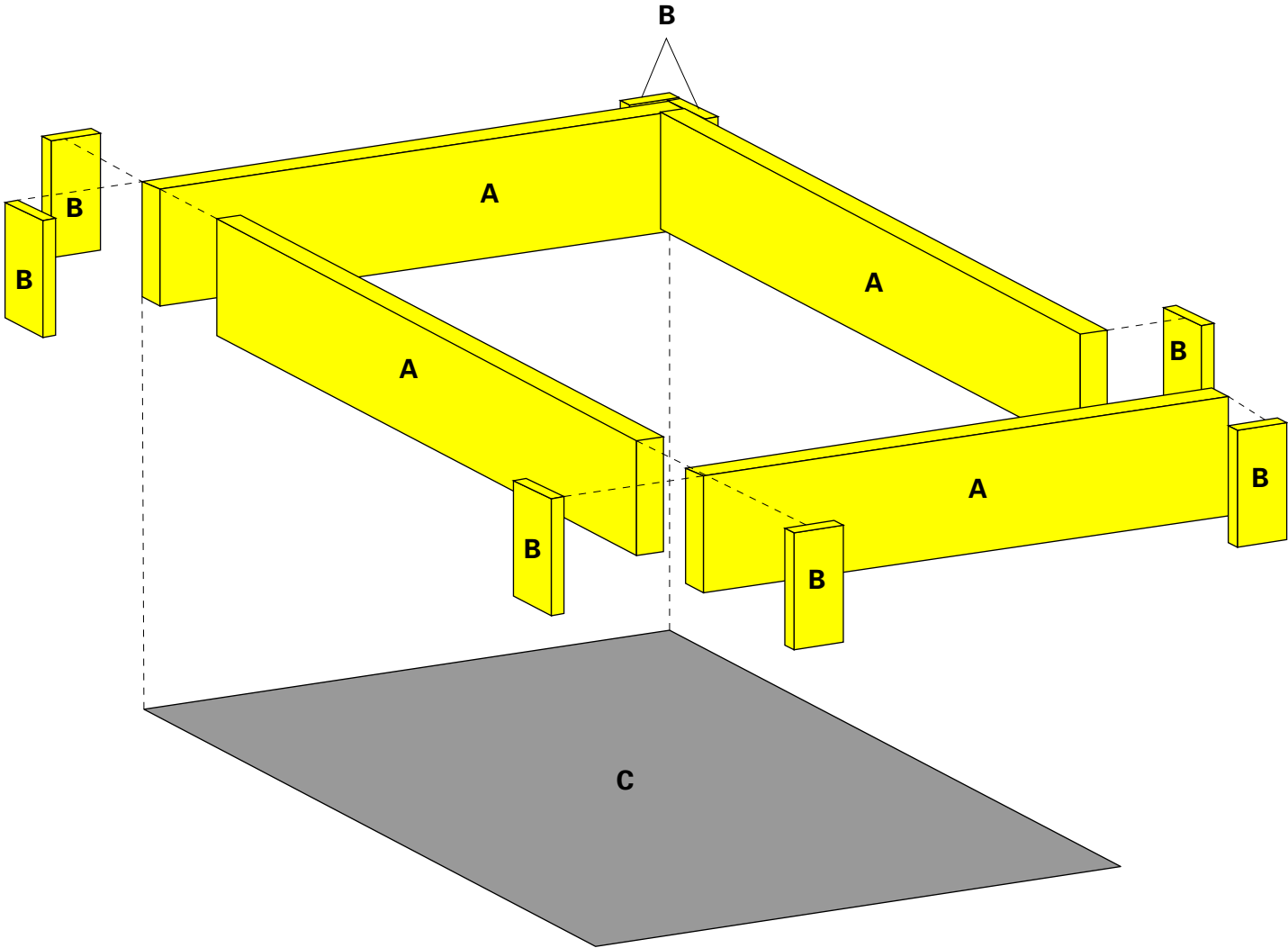

Raised Veggie Bed

YellaWood
Pressure Treated Pine

BUILDING STEPS

- 01** Cut four lengths of 2 x 8 at 24" for the sides (A). You should be able to do this with a single eight-footer, which usually measure at least 96 ½", if not more. Drill pilot holes in both ends of two side pieces where they will connect to the ends of the other two side pieces.
- 02** Connect the sides with 3" deck screws, keeping the outside faces flush with the ends. It will help to do this on a flat surface to keep the bottom edges flush with each other. Those will then become a nice, level top when you flip the assembly over.
- 03** Cut eight corner trim pieces (B) from 1 x 4 to a length 7 ½" and place each piece at the corners so they overlap the corner joints of the box assembly (see detail illustration). Attach with 1 ½" galvanized brads or finish nails.
- 04** Attach a piece of landscape fabric to the top edges (those that will eventually become the bottom) with galvanized staples. Let the fabric sag, as you want to leave room for the fabric to sag and settle with the eventual weight of your planting mix. Trim edges with a utility knife after you've driven all your staples flush.
- 05** Turn over and break all edges/sand all surfaces to eliminate splinters. Apply a weatherproof finish if desired, and place in your new planting spot, add the potting mix of your choice, plant and tend!
- 06** We recommend long lasting YellaWood Protector® semi-transparent stain and water repellent wood sealer, the only stain backed by the famous Yella Tag. Follow manufacturer's recommendations for application.



FASTENER AND HARDWARE INFORMATION SHEET

YellaWood®
Pressure Treated Pine

For interior or exterior applications

Use fasteners and hardware that are in compliance with the manufacturer's recommendations and the building codes for their intended use. As with any good design and construction practices, treated wood should not be used in applications where trapped moisture or water can occur. Where design and/or actual conditions allow for constant, repetitive or long periods of wet conditions, only stainless steel fasteners should be used.

For exterior applications

The following minimum galvanization levels may be used for connectors, joist hangers, fasteners and other hardware that are placed in direct contact with exterior applications of micronized copper treated wood:

- **Fasteners** - nails, screws, etc.
ASTM – A 153 (1 oz/ft²)
- **Hardware** - connectors, joist hangers, etc.
ASTM – A 653 G90 (0.90 oz/ft²)

The effects of other building materials within a given assembly, along with environmental factors, should also be considered when selecting the appropriate hardware and fasteners to use for a given project containing treated wood.

Stainless Steel fasteners and hardware are required for Permanent Wood Foundations below grade and are recommended for use with treated wood in other severe exterior applications such as swimming pools, salt water exposure, etc. - Type 304 and 316 are recommended grades to use.

Aluminum building products may be placed in direct contact with YellaWood® brand products used for interior uses and above ground exterior applications such as decks, fencing, and landscaping projects. Examples of aluminum products include siding, roofing, gutters, door and window trim, flashing, nails, fasteners and other hardware connectors. However, direct contact of treated products and aluminum building products should be limited to code-compliant construction applications that provide proper water drainage and do not allow the wood to be exposed to standing water or water immersion.

We recommend you contact the aluminum building products manufacturer for its recommendations regarding use of its aluminum products in contact with treated wood in ground contact applications or when exposed to salt water, brackish water, or chlorinated water, such as swimming pools or hot tubs.

Also check with the aluminum building products manufacturer regarding compatibility with other chemicals and cleaning agents and the use of their aluminum products in commercial, industrial, and specialty applications such as boat construction.

YellaWood® brand pressure treated products are treated with preservatives (the "Preservatives") and preservative methods and technologies of unrelated third parties. For details regarding the Preservatives, methods, and technologies used by Great Southern Wood Preserving, Incorporated, see www.yellowood.com/preservative or write us at P.O. Box 610, Abbeville, AL 36310. Ask dealer for warranty details. For warranty or for important handling and other information concerning our products including the appropriate Safety Data Sheet (SDS), please visit us at www.yellowood.com/warranties or write us at P.O. Box 610, Abbeville, AL 36310. YellaWood®, YellaWood Protector® and the yellow tag are federally registered trademarks of Great Southern Wood Preserving, Incorporated.

Great Southern Wood Preserving, Incorporated makes no warranties expressed or implied as to the fitness for a particular purpose of this plan.

IMPORTANT INFORMATION

YellaWood®
Pressure Treated Pine

- Consult the end tag to determine which preservative or preservative system was used in the treatment of that particular product. YellaWood® brand products may be used in direct contact with aluminum building products when limited to code-compliant construction applications that provide proper water drainage and do not allow the wood to be exposed to standing water or water immersion.
- Use fasteners and other hardware that are in compliance with building codes for the intended use.
- Do not burn preserved wood.
- Wear a dust mask and goggles when cutting or sanding wood.
- Wear gloves when working with wood.
- Some preservative may migrate from the treated wood into soil/water or may dislodge from the treated wood surface upon contact with skin.
- Wash exposed skin areas thoroughly.
- All sawdust and construction debris should be cleaned up and disposed of after construction.
- Wash work clothes separately from other household clothing before reuse.
- Preserved wood should not be used where it may come into direct or indirect contact with drinking water, except for uses involving incidental contact such as fresh water docks and bridges.
- Do not use preserved wood under circumstances when the preservative may become a component of food, animal feed or beehives.
- Do not use preserved wood as mulch.
- Only preserved wood that is visibly clean and free of surface residue should be used.
- If the wood is to be used in an interior application and becomes wet during construction, it should be allowed to dry before being covered or enclosed.
- If you desire to apply a paint, stain, clear water repellent or other finish to your preservative-treated wood, we recommend following the manufacturer's instructions and label of the finishing product. Before you start, we recommend you apply the finishing product to a small exposed test area before finishing the entire project to ensure it provides the intended result before proceeding.
- Mold growth can and does occur on the surface of many products, including untreated and treated wood, during prolonged surface exposure to excessive moisture conditions. To remove mold from the treated wood surface, wood should be allowed to dry. Typically, mild soap and water can be used to remove remaining surface mold. For more information visit www.epa.gov.
- Projects should be designed and installed in accordance with federal, state and local building codes and ordinances governing construction in your area, and in accordance with the National Design Specifications (NDS) and the Wood Handbook.

Disposal Recommendations:

Preserved wood may be disposed of in landfills or burned in commercial or industrial incinerators or boilers in accordance with federal, state and local regulations.