

Picnic Table

PROJECT PLAN

YellaWood
Pressure Treated Pine



Turns every meal into an outdoor experience.

This project makes a table that features seating for up to eight adults with separate benches for unencumbered leg room.

It all starts with constructing the table and bench tops, followed by the leg systems. The half-lap joints on the legs are easy to create and add a touch of charm.

A final sanding and coating of protection will have this table ready for action.

An easy weekend project, this set will soon become the central gathering point for your backyard.

BUILD TIME

6
HRS

DIFFICULTY



COST

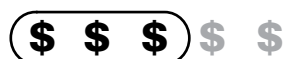

Picnic Table

IMPORTANT REMINDERS

YellaWood
Pressure Treated Pine

Read instructions to familiarize yourself with the entire process before beginning.

Always double check measurements before making cuts - Great Southern Wood is not responsible for incorrect cuts.

Select and use the best faces of boards on the outside of assemblies.

Pre-drill holes before attaching screws. Set $\frac{1}{8}$ " drill bit inside combination countersink bit to appropriate depth for each screw length called for.

Wood glue is optional: if you choose to use it, apply to surfaces before attaching parts, and be sure to wipe up excess with a damp cloth.

Check BuildYella.com for updates to plans and to view the video of this project.

Because wood stock can vary, dry-fit sub-assemblies as needed to ensure dependent parts align. Make any adjustments needed to part dimensions before final assembly.

The Cut List is based on the following actual dimensions for KDAT board stock:

1x2	$\frac{3}{4}$ " x $1\frac{1}{2}$ "
1x4	$\frac{3}{4}$ " x $3\frac{1}{2}$ "
1x6	$\frac{3}{4}$ " x $5\frac{1}{2}$ "
1x8	$\frac{3}{4}$ " x $7\frac{1}{4}$ "
$\frac{5}{4}$x6	$\frac{7}{8}$ " x $5\frac{1}{4}$ "
2x2	$1\frac{1}{2}$ " x $1\frac{1}{2}$ "
2x4	$1\frac{3}{8}$ " x $3\frac{1}{4}$ "
2x6	$1\frac{3}{8}$ " x $5\frac{1}{4}$ "
2x10	$1\frac{1}{2}$ " x $9\frac{1}{8}$ "
4x4	$3\frac{1}{4}$ " x $3\frac{1}{4}$ "

Picnic Table

OVERALL SIZE

YellaWood
Pressure Treated Pine

FRONT

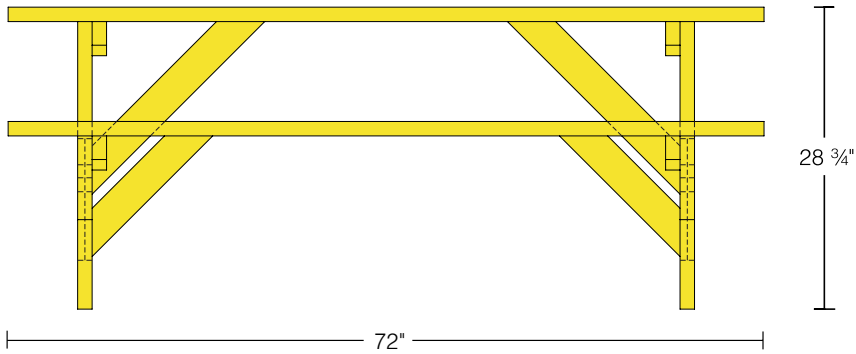

TOP

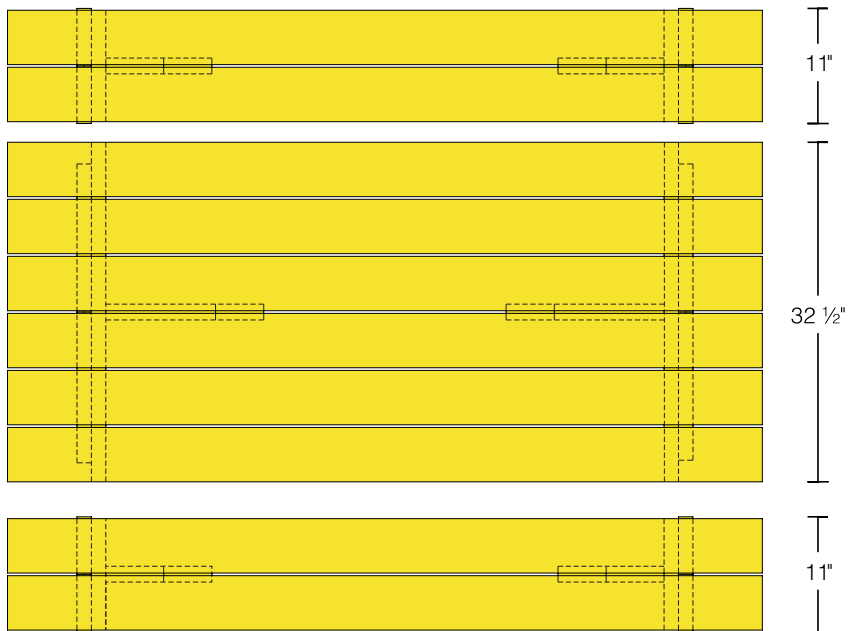

SIDE

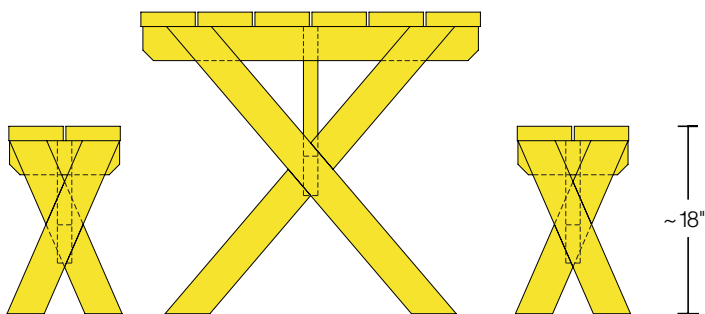

Note: Diagrams not to scale.

Picnic Table

OVERVIEW OF STEPS

YellaWood
Pressure Treated Pine

SEQUENCE OF BUILD

1: TOP SURFACES



2: LEG ASSEMBLIES



3: ASSEMBLY



4: FINISHING



BUILD TIME

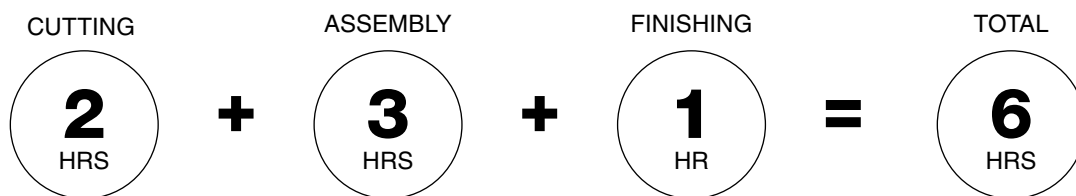

Picnic Table

WHAT YOU'LL NEED

YellaWood®
Pressure Treated Pine

MATERIALS

- 10x** 2x6x8' YellaWood® brand pressure treated pine
- 5x** 2x4x10' YellaWood® brand pressure treated pine

HARDWARE

½ LB BOX

- 1 ¼" wood screws + appropriate bit

1 BOX (approx. 70 screws)

- 4" heavy-duty wood lag screws (check size of head to determine hex driver)*

CARRIAGE BOLTS

- 12x** ¼" x 3 ½" galvanized carriage bolts
- 6x** ¼" x 4 ½" galvanized carriage bolts
- 18x** ¼" galvanized washers and nuts

OTHER

- 12x** 2" x 5" corner tie-plates
- 72x** ¼" Phillips pan-head screws + Phillips driver bit

WOOD FINISHING

- YellaWood Protector® Stain & Sealer

SAFETY EQUIPMENT

- Work gloves
- Dust mask
- Safety glasses
- Ear protection

Notes:

Consider using YellaWood® brand KDAT and higher grade products to achieve more professional results.

Choose boards with minimal irregularity to get the most out of the stock. The cut list shows maximum nesting of parts per board. If unsure about board quality, purchase 1 extra piece of each board type.

If you'd like to construct the HACK version of this plan, skip ahead and add that material list to your purchase list.

TOOLS



Pencil



Measuring tape



Miter saw
(or chop saw)



Combination
countersink bit
(with ⅛" bit)



Drill / driver



Clamps
(two at least 5' long)



Chisel or file



Hammer

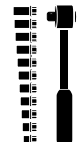

Socket wrench
(with a 7/16" bit)



3/16" & ¼"
Drill bits
(to pre-drill for lag screw:
check diameter*)

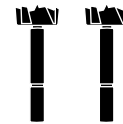

½" & 1"
Forstner bits
(for countersinking lag
screw head*)



Hex driver bit
(fits lag screw head*)



Radial sander
(or sanding block)



Paint/Stain
Brush

Picnic Table

CROSS-CUT DIAGRAMS



PREP: CROSS-CUT ALL PARTS

Proceed to cut all parts listed below unless noted otherwise. Be sure to **label all parts** so you know which ones to use for the Assembly Steps that follow.



CROSS-CUT TO	PART	#
72"	A	10x

2x6x8' STOCK 10 BOARDS

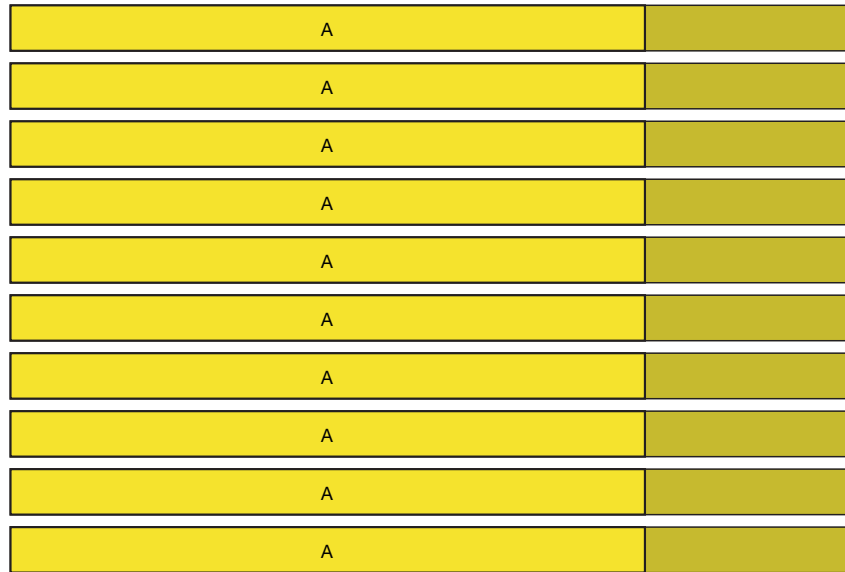

CROSS-CUT TO	PART	#
32"	B*	2x
10 1/2"	C*	4x
38 3/4"	D*	4x
19 1/2"	E*	8x
23 1/4"	F*	2x
16 1/4"	G*	4x

2x4x10' STOCK 5 BOARDS

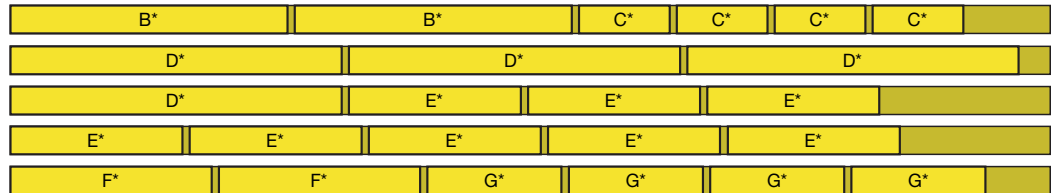

* Requires detail cuts - see next page

Note: Diagrams not to scale.

Picnic Table

YellaWood
Pressure Treated Pine

DETAIL CUT DIAGRAMS

PREP: DETAIL CUT PARTS

Proceed to cut all parts listed below unless noted otherwise. Be sure to **label all parts** so you know which ones to use for the Assembly Steps that follow.



ANGLE CUT TO	PART	#
45°	B	2x
45°	C	4x
38°	D	4x
22 1/2°	E	8x
45°	F	2x
45°	G	4x

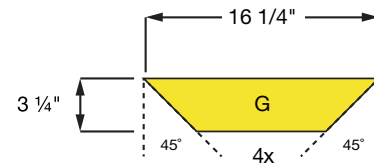
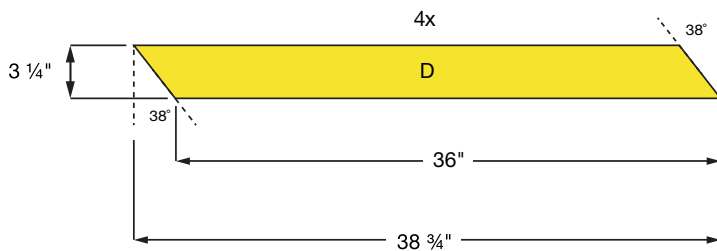
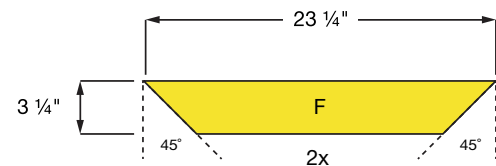
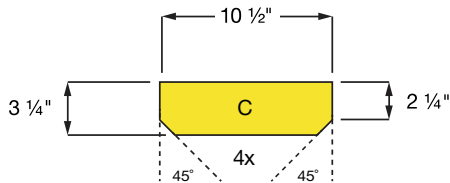
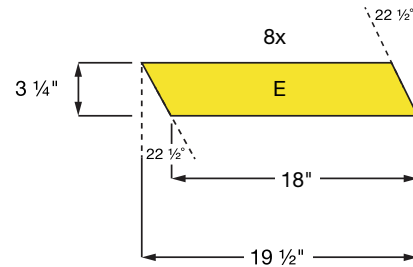
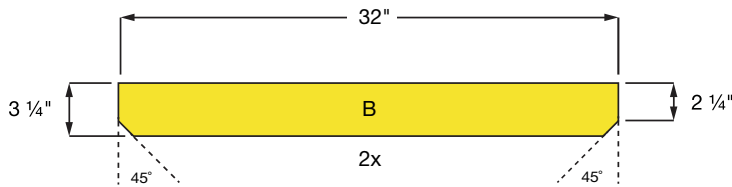

Note: Diagrams not to scale.

Picnic Table

LAYOUT DIAGRAMS

YellaWood
Pressure Treated Pine

BENCH LEG ASSEMBLY - FRONT

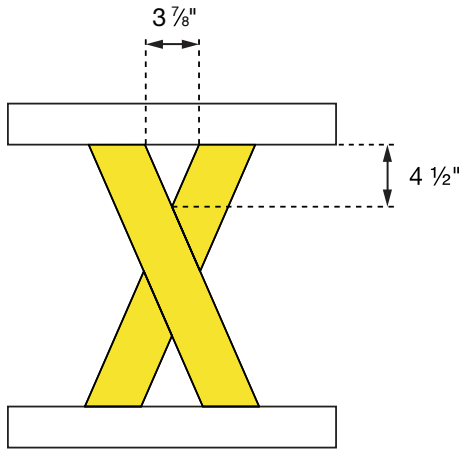

Spare piece of wood used to block up both ends. Ensure they are both 90° to each other.

TABLE LEG ASSEMBLY - FRONT

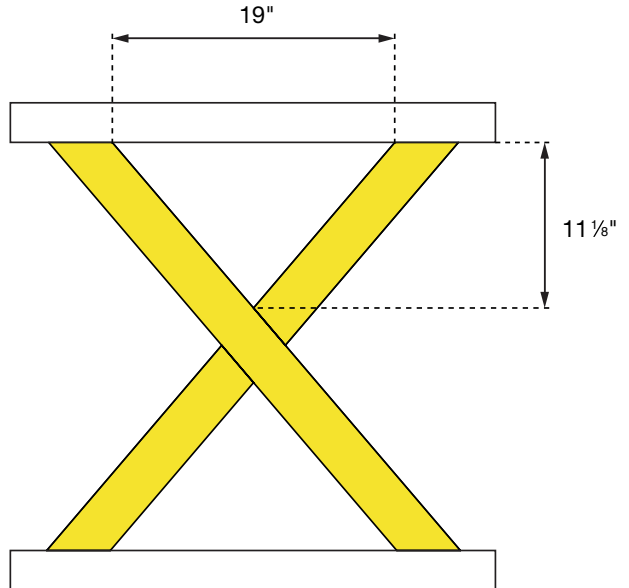

BENCH LEG ASSEMBLY - SIDE

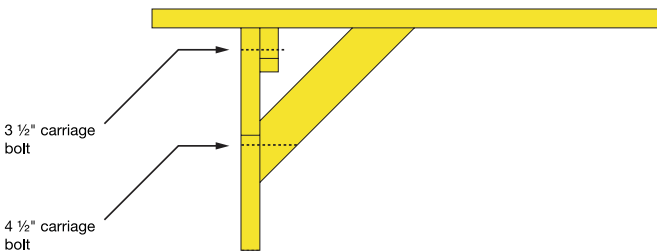
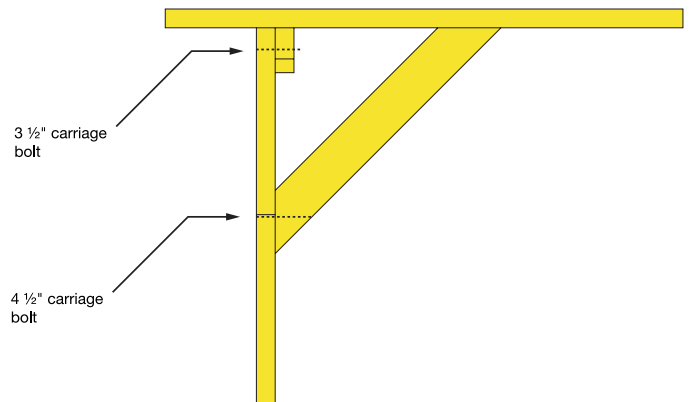

TABLE LEG ASSEMBLY - SIDE



Note: Diagrams not to scale.

Picnic Table

ASSEMBLY

YellaWood
Pressure Treated Pine

SECTION 1: TOP SURFACES

TOOLS



Drill / driver



Pencil



Measuring
tape



Clamps
(at least 5' long)



Hex driver
(fits lag screw head)



3/16" drill bit
(fits lag screw head)



1/2 " Forstner
bit

SUPPLIES



4" heavy-duty lag screws

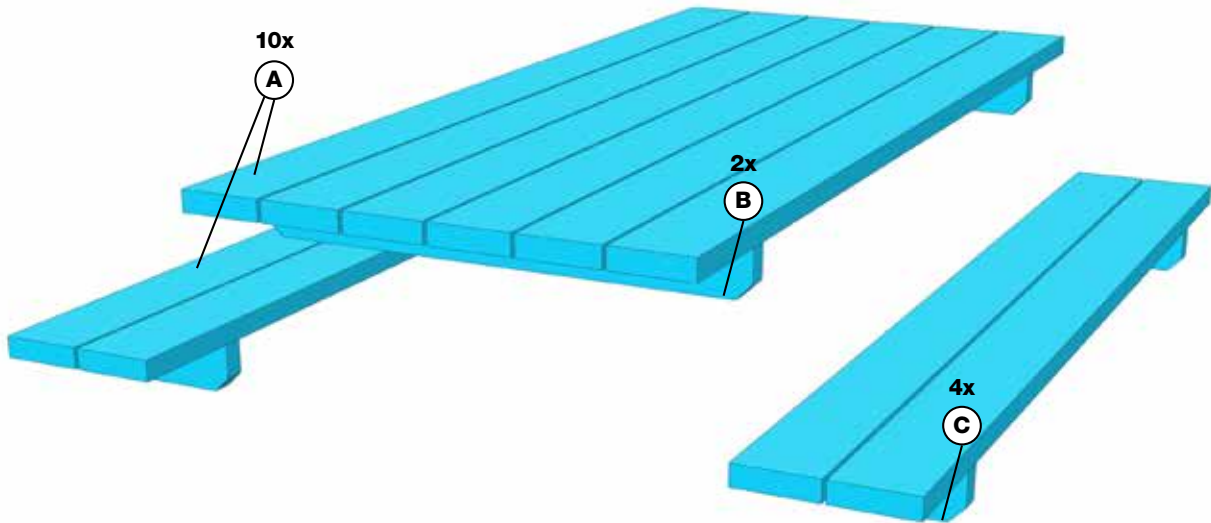

Picnic Table

ASSEMBLY

SECTION 1: TOP SURFACES

1



Begin by laying out six Parts (A), checking that the grain curves are opposite for boards next to each other. Use $\frac{1}{4}$ " spacers between the boards and tighten with a 5' bar clamp.

2



Place a Part (B) at either end of the table at 8" from the ends. Be sure Part (B) is oriented as shown in the image above, where angled faces are facing up.

3



Using a $\frac{1}{2}$ " forstner bit, drill to a depth of $\frac{1}{2}$ " so that the heavy-duty lag screws are sub-flush when installed. Then, use a $\frac{3}{16}$ " drill bit to pre-drill.

4



Using the appropriate hex bit, secure Part (B) to Parts (A) using two 4" lag screws per board. Continue down the width of the table until all boards are secured.

5



Repeat Steps 3 and 4 on the other end of the table surface.

6



Start the bench top assembly using the same techniques as with the table. Arrange two Parts (C) on top of Parts (A) with the same spacing of 8" away from the edges of (A). Use clamps as needed.

7



Countersink with the forstner bit, pre-drill with the $\frac{3}{16}$ " bit, and secure with two 4" lag screws per board.

8



Repeat at the other end of the bench.

9



Make a second bench top in the same manner.

Picnic Table

ASSEMBLY

YellaWood
Pressure Treated Pine

SECTION 2: LEG ASSEMBLIES

TOOLS



Drill / driver



Pencil



Measuring
tape



Miter saw
(or chop saw)



Chisel or file



Combination
countersink bit
(with 1/8" bit)



Clamps
(two at least 5'
long)

SUPPLIES



1 1/4" screws

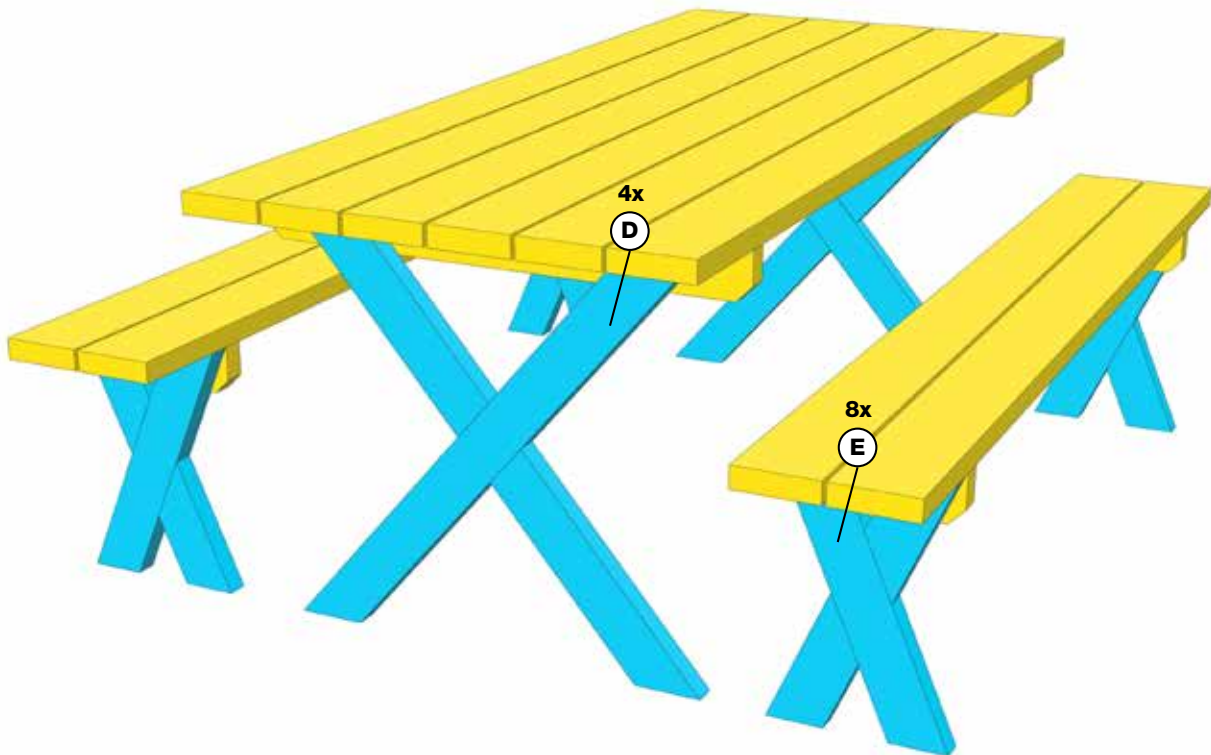

Picnic Table

ASSEMBLY

SECTION 2: LEG ASSEMBLIES

10



Take two Parts (D) and make an "X" on the work surface, blocking up the edges with scrap pieces of wood. See Diagram Page for dimensional layout of parts.

11



Hold in place and mark one of the legs on both sides with a pencil.

12



Set the miter saw to the degree that matches the lines drawn on the leg. It should be close to 9° for the table legs and 43° for the bench legs, but direct-measure your pieces.

13



Set the depth of the saw blade to half of the board thickness, or $\frac{1}{16}$ " , and tighten the stop bolt so that the blade will only cut this deep.

14



Carefully slide the saw blade through the wood at half-depth within the two line marks until the entire section is cut. Use a scrap piece of wood behind the leg so the saw cuts all the way through.

15



Chisel or file the ridges of the saw blade marks and test fit onto another 2x4 to ensure a good fit.

16



Place the cut leg on top of its mate and mark the uncut leg. Take this leg to the saw and repeat steps 14 and 15. Make lap joints for all Part (D)s and all eight Part (E)s - see Diagrams Page for bench leg layout.

17



Mate each table leg pair and secure with two $1\frac{1}{4}$ " diagonally-placed screws.

18



Repeat step 17 for the four bench leg assemblies.

Picnic Table

ASSEMBLY

YellaWood
Pressure Treated Pine

SECTION 3: ASSEMBLY

TOOLS



Drill / driver



Pencil



Measuring
tape



Socket wrench
(with 7/16" bit)



Hammer



1/4" Drill bit



1" Forstner bit



Clamps
(two at least 5'
long)

SUPPLIES



12x 2" x 5"
corner tie-plates

12x 1/4" x 3 1/2"
carriage bolts

72x 1/2" pan-head
screws + Phillips
bit

6x 1/4" x 4 1/2"
carriage bolts

18x 1/4" washers
and nuts

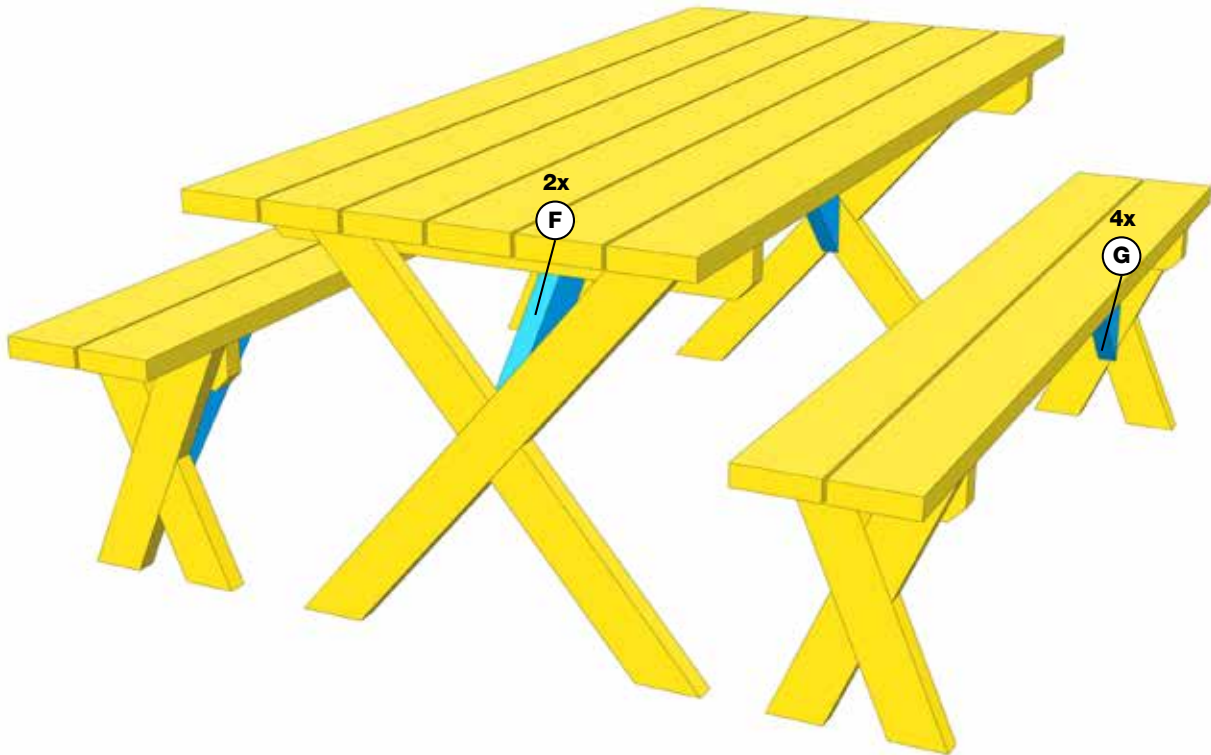

Picnic Table

ASSEMBLY

YellaWood
Pressure Treated Pine

SECTION 3: ASSEMBLY

19



Center a table leg assembly on the outside of Part (B) on the table surface and secure with a clamp. Avoiding the lag bolts, drill a $\frac{1}{4}$ " hole through Part (B) and both 2x4 legs.

20



Put a $\frac{1}{4}$ " x $3\frac{1}{2}$ " carriage bolt through the hole and tap it in to place with a hammer.

21



Secure the bolt with a washer and nut and tighten. Do this on the other side of the leg as well.

22



Repeat steps 19 - 21 to assemble the other table leg.

23



Next add the brace, Part (F), centered within the "X" of the leg assembly. Avoiding the two screws that secure the leg assembly, drill a $\frac{1}{4}$ " hole through the legs and Part (F) until you've tapped Part (F).

24



Then, to make it easier to drill, pull off Part (F) and complete the drilling operation, maintaining the correct angle.

25



Use a 1" forstner bit to create depth for the washer and nut, and then secure with a $\frac{1}{4}$ " x $4\frac{1}{2}$ " carriage bolt, washer and nut. Use a $\frac{7}{16}$ " socket wrench. Repeat these steps for the table and benches.

26



Lastly, secure 90° tie-plates with $\frac{1}{2}$ " pan-head screws to stabilize the other end of the brace. Use one per side, positioning it so that the edges do not poke out. Use six screws per tie-plate, totaling 72 screws.

27



Do the same processes (steps 19 -26) to both bench seats, substituting $3\frac{1}{2}$ " carriage bolts for the $4\frac{1}{2}$ " ones mentioned in step 25.

Picnic Table

FINISHING

YellaWood®
Pressure Treated Pine

SECTION 4: FINISHING



TOOLS



Radial sander
(or sanding block)



Paint/Stain
Brush

YellaWood® brand products provide the best available pressure treated lumber protection against rot, fungal decay and termites. Sanding edges is recommended to reduce snags and splintering. At a minimum, we recommend annual application of a water repellent. You can also paint or stain it if you prefer.

28



Ease any sharp edges using a radial sander or sanding block with medium grit. Apply preferred finish to the wood.

29



We recommend long lasting YellaWood Protector® semi-transparent stain and water repellent wood sealer, the only stain backed by the famous Yella Tag. Follow manufacturer's recommendations for application.

CONGRATULATIONS. ENJOY YOUR NEW PICNIC TABLE!

Picnic Table

GALLERY OF IMAGES

YellaWood
Pressure Treated Pine



Picnic Table // Hack

PROJECT PLAN

YellaWood
Pressure Treated Pine



No shade? No problem. Add an ice trough with this clever hack.

Tackle this hack project if you'd like to have a cool place to store drinks right in your picnic table.

This trough adds sophistication to the casual table, and its angled walls allow for bottles to lay elegantly. With ice and a removable plug, it can be used to keep drinks cool during an entire event.

After two boards and braces are removed, the trough is constructed out

of wood and then lined with roof flashing for water protection. Then the trough is attached to the table and a lid is built to cover the trough when not in use.

An obvious upgrade to your picnic table project, this drink trough will last for years to come.

BUILD TIME

3
HRS

DIFFICULTY



COST



Picnic Table // Hack

YellaWood
Pressure Treated Pine

OVERALL SIZE

SIDE

51 1/4"



LID

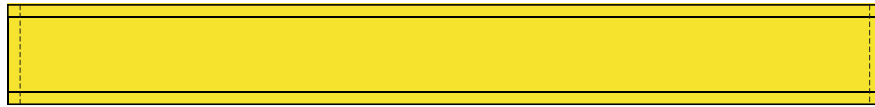

TROUGH

53 1/4"

TOP

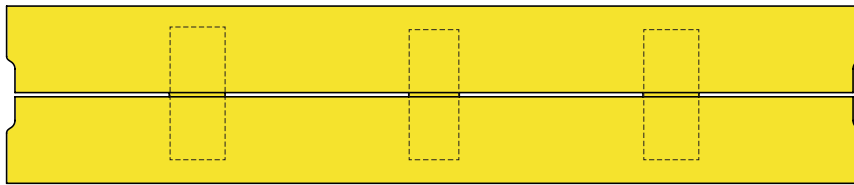

10 1/2"

LID

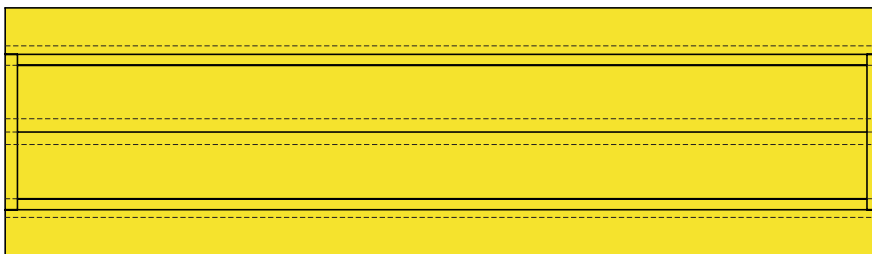

16"

TROUGH

FRONT



1 1/2"

LID

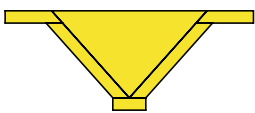

6"

TROUGH

NOTE

Not shown:

- 1x4 pieces - Parts (O) - to secure short boards on the outside of the trough
- New braces (cut from existing)

Note: Diagrams not to scale.

Picnic Table // Hack

OVERVIEW OF STEPS

YellaWood
Pressure Treated Pine

SEQUENCE OF BUILD

1: REMOVE BOARDS & BRACES



2: BUILD & INSTALL TROUGH + BRACES



3: BUILD LID & ENDS



4: FINISHING



BUILD TIME

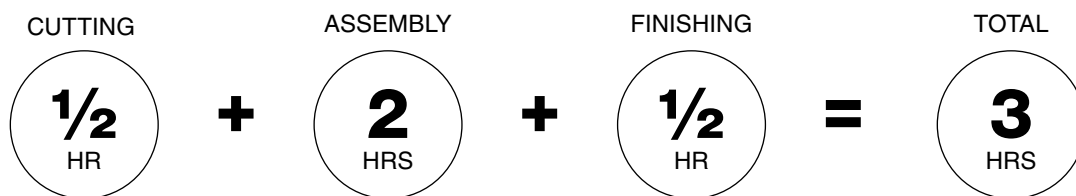

Picnic Table // Hack

WHAT YOU'LL NEED



MATERIALS

- 2x** 1x8x8' YellaWood® brand pressure treated pine
- 3x** 1x4x10' YellaWood® brand pressure treated pine

HARDWARE

- Phillips bit to remove pan-head screws
- 1 ¼" wood screws + appropriate bit
- 1 ⅝" wood screws + appropriate bit

OTHER

- 1 ⅝" rubber stopper
- 14" roll of roof flashing
- Tube of construction cement
- Tube of silicone caulk

WOOD FINISHING

- YellaWood Protector® Stain & Sealer

TOOLS



Pencil



Measuring tape



Miter saw
(or chop saw)



Table saw



Jig saw



1 ⅛" Forstner bit



Drill / driver



Clamps



Combination countersink bit
(with ⅛" bit)



Hammer



Socket wrench
(with a 7/16" bit)



Hex driver bit
(fits lag screw head*)



Metal snips



Radial sander
(or sanding block)



Rag
(to wipe up caulk and adhesive)



Pocket screw jig
(optional)



Caulk gun



Paint/Stain brush

SAFETY EQUIPMENT

- Work gloves
- Dust mask
- Safety glasses
- Ear protection

Notes:

Consider using YellaWood® brand KDAT and higher grade products to achieve more professional results.

Choose boards with minimal irregularity to get the most out of the stock. The cut list following this page shows maximum parts per board. If unsure about board quality, purchase 1 extra piece of each board type.

Picnic Table

CROSS-CUT DIAGRAMS

PREP: CROSS-CUT ALL PARTS

Proceed to cut all parts listed below unless noted otherwise. Be sure to **label all parts** so you know which ones to use for the Assembly Steps that follow.



CROSS-CUT TO	PART	#
53 3/4"	H*	2x
10 1/2"	I*	2x

1x8x8' STOCK 2 BOARDS

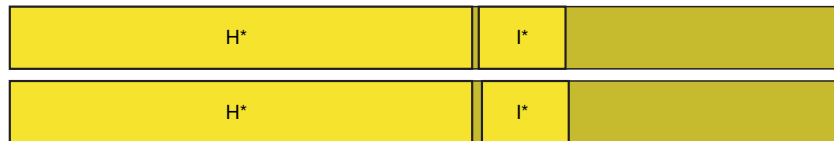

CROSS-CUT TO	PART	#
53 3/4"	J*	2x
53 3/4"	K*	1x
19"	L	2x
7 1/2"	M	3x

1x4x10' STOCK 3 BOARDS

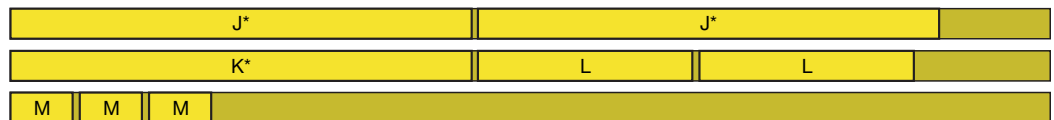

* Requires detail cuts - see below and next page

PREP: DETAIL CUTS



RIP-CUT

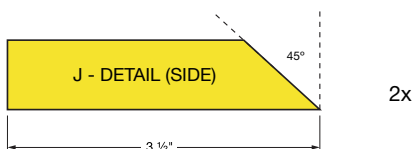
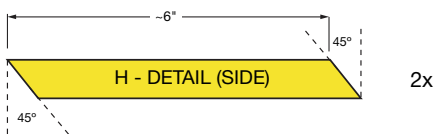

ANGLE CUT

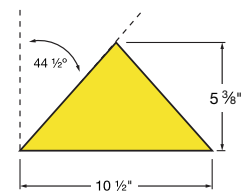

Note: Diagrams not to scale.

Picnic Table

DETAIL CUT DIAGRAMS

YellaWood
Pressure Treated Pine

PREP: CROSS-CUT EXISTING PARTS

*Parts (O) and (N) come from removing the two middle boards - referred to as Parts (A) - from the picnic table, and cutting along the dashed lines as indicated.

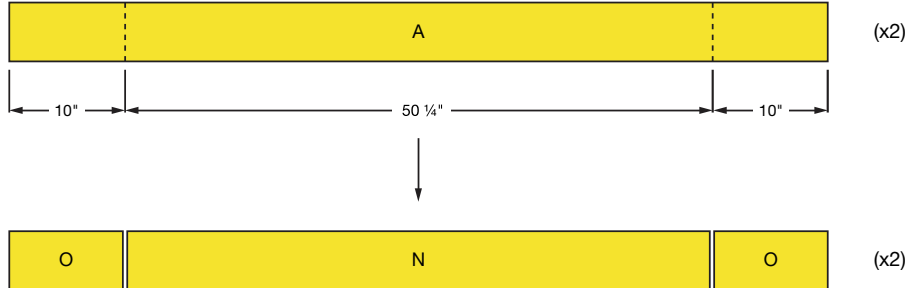

*Parts (P) come from removing the two diagonal braces from underneath the table - referred to as Parts (F) - from the picnic table and cutting along the dashed line as indicated.

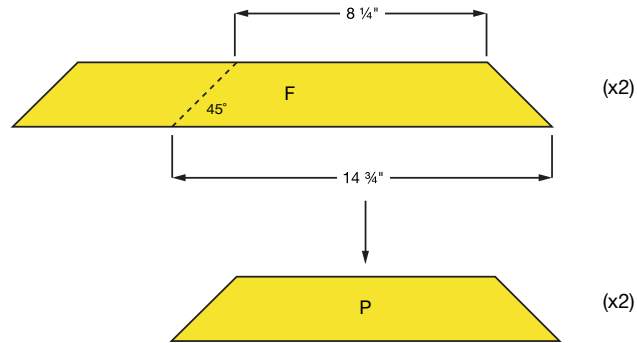

PREP: FINAL DETAIL CUTS



JIGSAW CUT

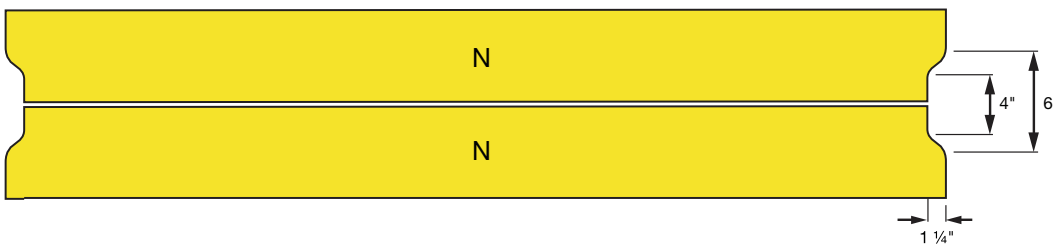

Note: Diagrams not to scale.

Picnic Table // Hack

YellaWood
Pressure Treated Pine

ASSEMBLY

INSTRUCTIONS FOR ALL SECTIONS

1



First, remove the two angle braces and the two center boards from the top of the picnic table. Use the socket wrench, Phillips bit, and hex bit to remove the fasteners.

2

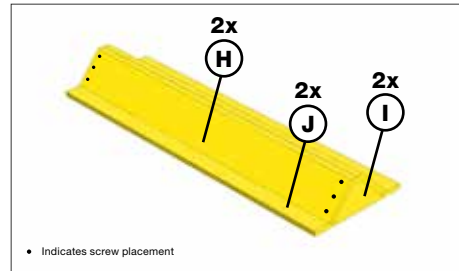

To create the trough, cut Parts (H), (I) and (J). Assemble these parts as shown, and clamp the outside edges of Parts (J) on a work surface. Attach Parts (H) to (I) with three 1 5/8" screws per edge at an angle.

3

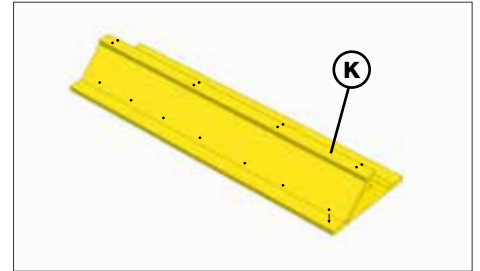

Attach Parts (J) with 1 1/4" screws at an angle per side (use a pocket screw jig if available). Attach (K) with 1 5/8" screws. Use a 1 1/8" forstner bit to cut a hole at one end of the trough about 1/4" from the point of Part (I).

4



Measure and cut roof flashing to fit on the inside four walls. Test each piece to ensure a good fit. Mark the hole cutout on one of the triangle pieces and use snips to cut.

5



Place the flashing on the walls after applying construction cement to the walls. Wipe any excess adhesive. Once dry, seal the seams with silicone caulk.

6

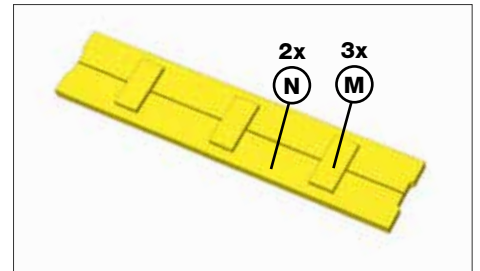

To create the lid, cut Parts (N) from the boards you removed in step 1. Use Parts (M) as battens, add a 1/4" spacer, and secure to Parts (N) with two 1 1/4" screws per board.

7



With the picnic table flipped over (get a friend to help), center upside-down trough and attach through Parts (J) into the table with 1 5/8" screws. Then secure new brace Part (P) with existing carriage bolts and toe-screw the end with two 1 5/8" screws.

8



Add Parts (L) to the outside of both leg assemblies with 1 5/8" screws. Attach the final four Parts (O) to Part (L) using four 1 5/8" screws per board.

9



Flip picnic table over with a friend's help and lay in the lid. Add the 1 1/8" plug to the trough.

CONGRATULATIONS. ENJOY YOUR NEW UPGRADED PICNIC TABLE!

Picnic Table // Hack

GALLERY OF IMAGES

YellaWood
Pressure Treated Pine



Picnic Table

FASTENER & HARDWARE INFORMATION



FOR INTERIOR OR EXTERIOR APPLICATIONS

Use fasteners and hardware that are in compliance with the manufacturer's recommendations and the building codes for their intended use. As with any good design and construction practices, treated wood should not be used in applications where trapped moisture or water can occur. Where design and/or actual conditions allow for constant, repetitive or long periods of wet conditions, only stainless steel fasteners should be used.

FOR EXTERIOR APPLICATIONS

The following minimum galvanization levels may be used for connectors, joist hangers, fasteners and other hardware that are placed in direct contact with exterior applications of micronized copper treated wood:

- **Fasteners** – nails, screws, etc. ASTM – A 153 (1 oz/ft²)
- **Hardware** – connectors, joist hangers, etc. ASTM – A 653 G90 (0.90 oz/ft²)

The effects of other building materials within a given assembly, along with environmental factors, should also be considered when selecting the appropriate hardware and fasteners to use for a given project containing treated wood.

Stainless Steel fasteners and hardware are required for Permanent Wood Foundations below grade and are recommended for use with treated wood in other severe exterior applications such as swimming pools, salt water exposure, etc. Type 304 and 316 are recommended grades to use.

ALUMINUM

Aluminum building products may be placed in direct contact with YellaWood® brand products used for interior uses and above ground exterior applications such as decks, fencing, and landscaping projects. Examples of aluminum products include siding, roofing, gutters, door and window trim, flashing, nails, fasteners and other hardware connectors. However, direct contact of treated products and aluminum building products should be limited to code-compliant construction applications that provide proper water drainage and do not allow the wood to be exposed to standing water or water immersion.

We recommend you contact the aluminum building products manufacturer for its recommendations regarding use of its aluminum products in contact with treated wood in ground contact applications or when exposed to salt water, brackish water, or chlorinated water, such as swimming pools or hot tubs.

Also check with the aluminum building products manufacturer regarding compatibility with other chemicals and cleaning agents and the use of their aluminum products in commercial, industrial, and specialty applications such as boat construction.

YellaWood® brand pressure treated products are treated with preservatives (the "Preservatives") and preservative methods and technologies of unrelated third parties. For details regarding the Preservatives, methods, and technologies used by Great Southern Wood Preserving, Incorporated, see www.yellowood.com/preservative or write us at P.O. Box 610, Abbeville, AL 36310. Ask dealer for warranty details. For warranty or for important handling and other information concerning our products including the appropriate Safety Data Sheet (SDS), please visit us at www.yellowood.com/warranties or write us at P.O. Box 610, Abbeville, AL 36310. YellaWood®, YellaWood Protector® and the yellow tag are federally registered trademarks of Great Southern Wood Preserving, Incorporated.

Great Southern Wood Preserving, Incorporated makes no warranties expressed or implied as to the fitness for a particular purpose of this plan.

Picnic Table

IMPORTANT INFORMATION



- Consult the end tag to determine which preservative or preservative system was used in the treatment of that particular product. YellaWood® brand products may be used in direct contact with aluminum building products when limited to code-compliant construction applications that provide proper water drainage and do not allow the wood to be exposed to standing water or water immersion.
- Use fasteners and other hardware that are in compliance with building codes for the intended use.
- Do not burn preserved wood.
- Wear a dust mask and goggles when cutting or sanding wood.
- Wear gloves when working with wood.
- Some preservative may migrate from the treated wood into soil/water or may dislodge from the treated wood surface upon contact with skin.
- Wash exposed skin areas thoroughly.
- All sawdust and construction debris should be cleaned up and disposed of after construction.
- Wash work clothes separately from other household clothing before reuse.
- Preserved wood should not be used where it may come into direct or indirect contact with drinking water, except for uses involving incidental contact such as fresh water docks and bridges.
- Do not use preserved wood under circumstances when the preservative may become a component of food, animal feed or beehives.
- Do not use preserved wood as mulch.
- Only preserved wood that is visibly clean and free of surface residue should be used. If the wood is to be used in an interior application and becomes wet during construction, it should be allowed to dry before being covered or enclosed.
- Mold growth can and does occur on the surface of many products, including untreated and treated wood, during prolonged surface exposure to excessive moisture conditions. To remove mold from the treated wood surface, wood should be allowed to dry. Typically, mild soap and water can be used to remove remaining surface mold. For more information visit www.epa.gov.
- Projects should be designed and installed in accordance with federal, state and local building codes and ordinances governing construction in your area, and in accordance with the National Design Specifications (NDS) and the Wood Handbook.

DISPOSAL RECOMMENDATIONS

Preserved wood may be disposed of in landfills or burned in commercial or industrial incinerators or boilers in accordance with federal, state and local regulations.