



## Craft a comfortable and sturdy outdoor retreat.

The daybed fits a twin mattress pad and it has built-in magazine and book racks on the sides. The design features notched legs and strong joints that make for a sturdy piece of furniture that will last.

You'll start with the construction of the legs, then move on to the platform and its decking. Then you'll finish the assembly by laying up the side, back, and top planks. Make sure to take proper safety precautions including always wearing gloves, goggles and a dust mask when you're cutting or sanding.

### BUILD TIME

**13**  
HRS

### DIFFICULTY



# Daybed

## WHAT YOU'LL NEED

**YellaWood®**  
Pressure Treated Pine

### TOOLS



Miter saw  
(or hand or circular saw)



Table saw

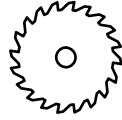

Dado blade &  
miter gauge for  
table saw

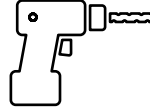

Drill / driver



1/8" Counter-sink  
drill bit



Measuring tape

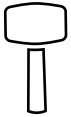

Mallet



Clamps

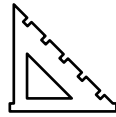

Carpenter's  
square



Damp rag (to wipe  
excess glue)



Paint/Stain Brush

### SUPPLIES

**2x**  
4x4-8' YellaWood® brand pressure  
treated pine

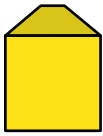

**6x**  
2x4-8' YellaWood® brand pressure  
treated pine

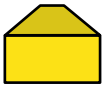

**22x**  
1x4-8' YellaWood® brand pressure  
treated pine



**200x**  
3" Galvanized  
deck screws



**200x**  
1-5/8" Galvanized  
deck screws



Waterproof  
wood glue

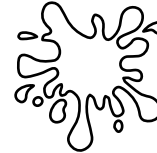

YellaWood Protector®  
Stain & Sealer



### BUILD TIME

Cutting

**5**  
HRS

+

Assembly

**5**  
HRS

+

Finishing

**3**  
HRS

=

Total

**13**  
HRS

# Daybed

## DIMENSIONS & DIAGRAMS

**YellaWood**<sup>®</sup>  
Pressure Treated Pine

**Note:**

All measurements are approximate. Cut stock in the sequence of steps because many dimensions are directly measured and will vary based on actual stock and construction.

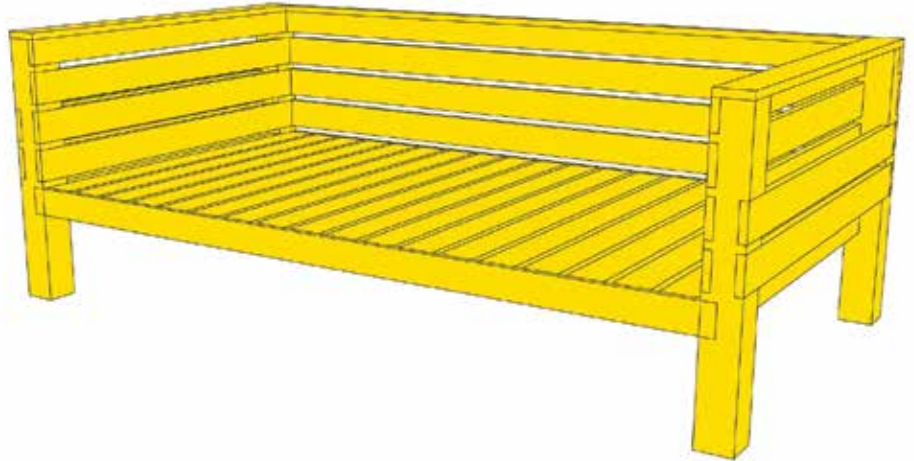

**TOP**

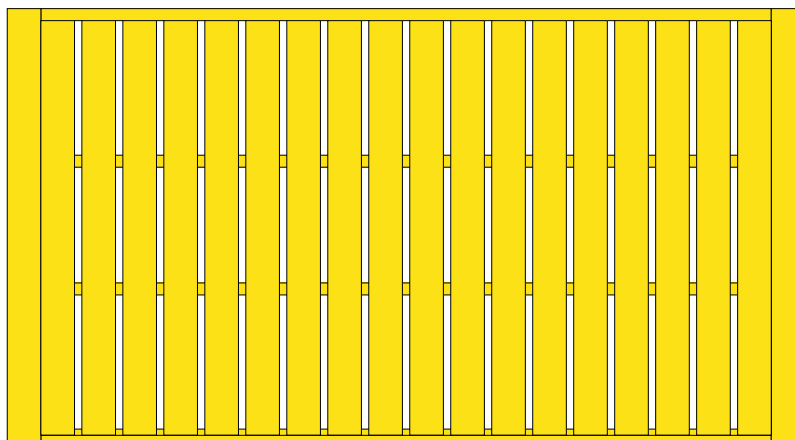

~45"

~83"

~45"

~30"

**FRONT**

**LEFT SIDE**

### LEGS: Front Left

SIDE VIEW

(4x) 4x4 stock

\* Stock dimensions vary. Directly measure all cutouts to fit your stock exactly.

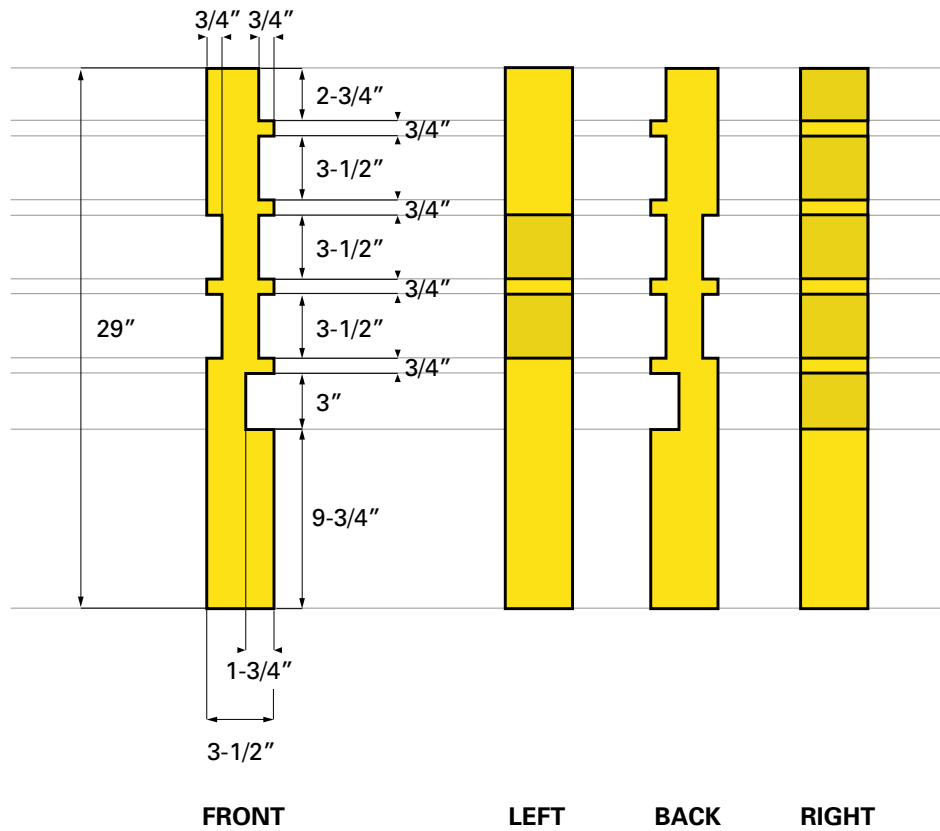

### LEGS: Front Right

SIDE VIEW

(4x) 4x4 stock

\* Stock dimensions vary. Directly measure all cutouts to fit your stock exactly.

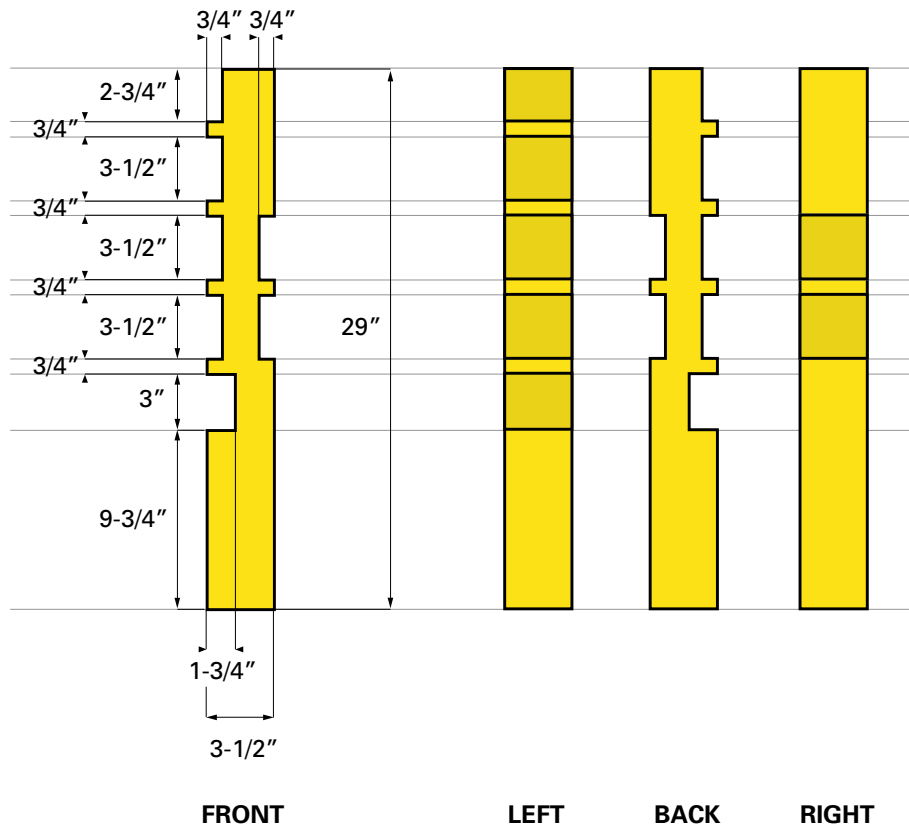



### LEGS: Back Right

SIDE VIEW

(4x) 4x4 stock

\* Stock dimensions vary. Directly measure all cutouts to fit your stock exactly.

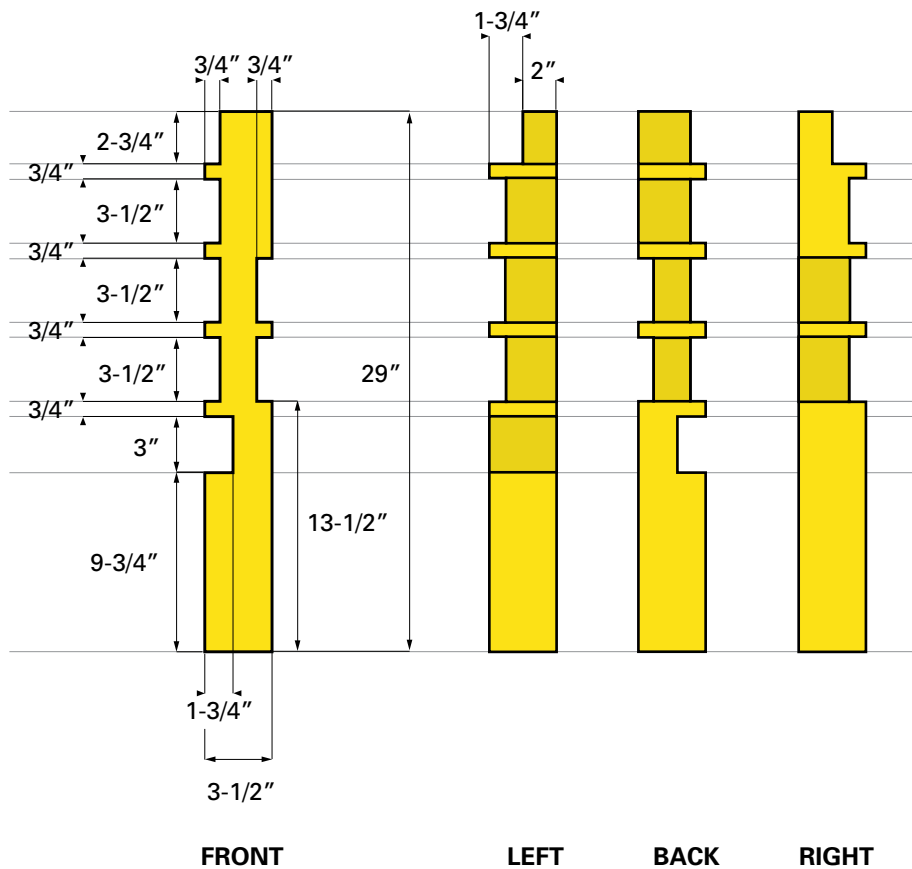

### PLATFORM

TOP VIEW

Frame

(6x) 2x4 stock



#### FRAME DETAIL CROSS SECTIONS

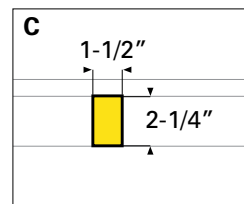
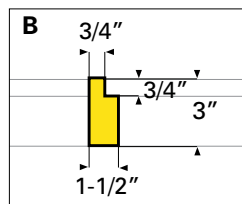
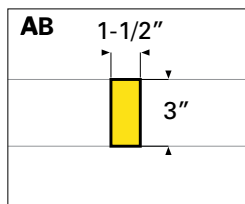



### PLATFORM

TOP VIEW

Decking  
(18x) 1x4 stock

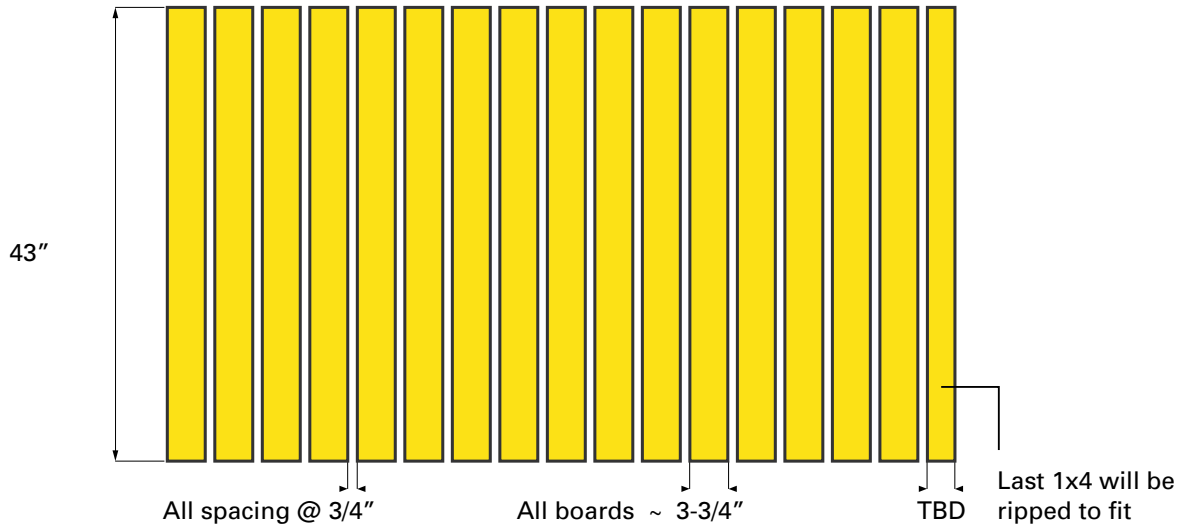

### SIDES

TOP VIEW

- A.**  
Inside Slats  
(4x) 1x4 stock
- B.**  
Outside Slats  
(2x) 1x4 stock
- C.**  
Outside Shelf Bottom  
(2x) 1x4 stock

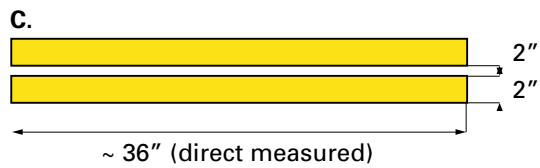
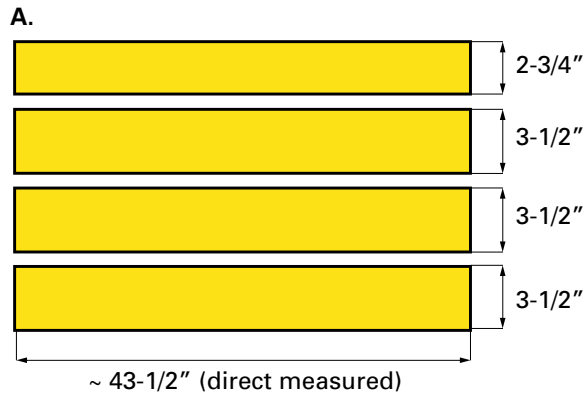

### BACK & TOPS

#### TOP VIEW

**A.**  
Top Slat  
(1x) 2x4 stock



**B.**  
Bottom Slats  
(4x) 1x4 stock

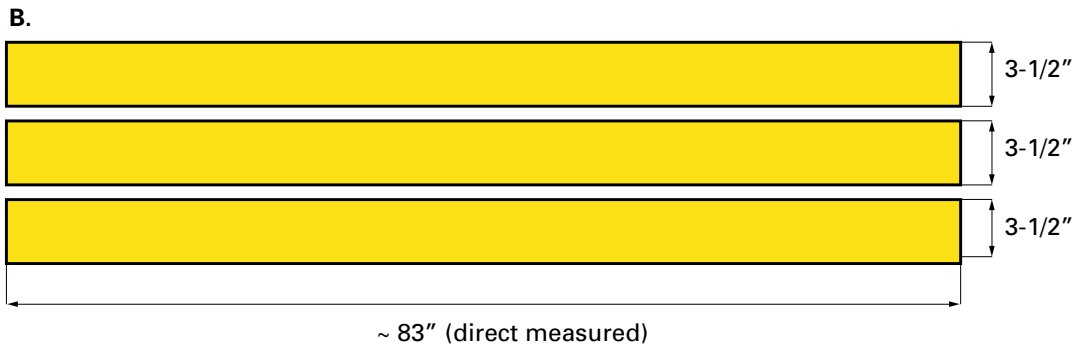

**C.**  
Back Cap Piece  
(1x) 1x4 stock

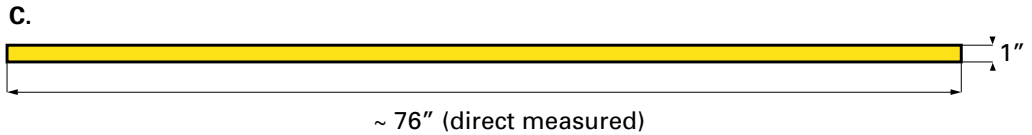

**D.**  
Side Cap Pieces  
(2x) 1x4 stock

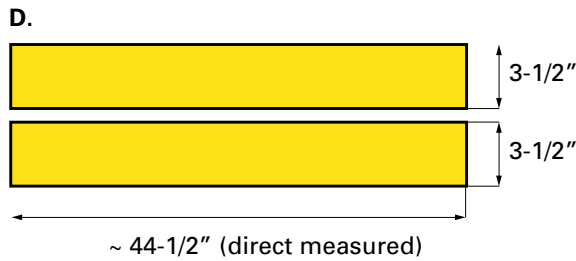

## STEP 1: LEGS

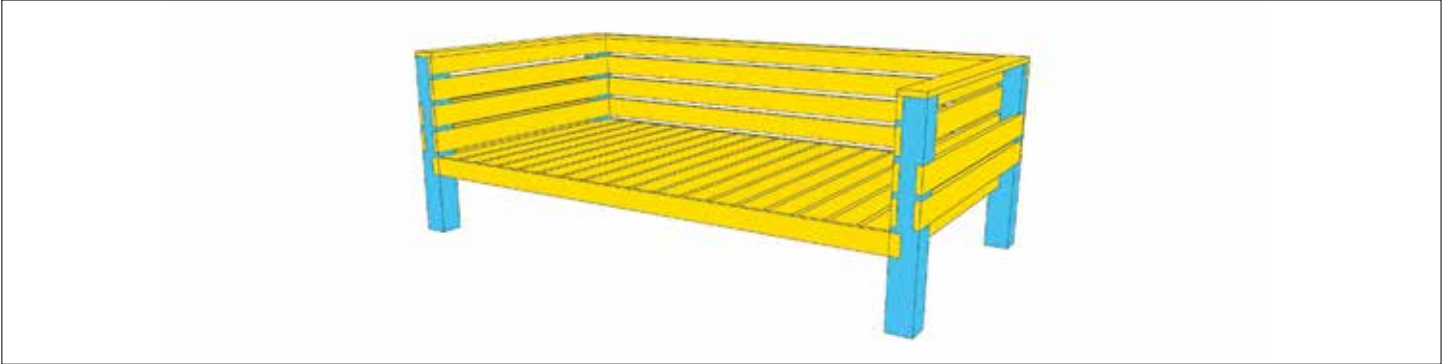

The first step is to make the leg cutouts. This can be a little complicated, but you can see a demonstration by watching the video at [buildyella.com/projects](http://buildyella.com/projects).

**A**



Crosscut the 4 legs from the 4x4 stock to a length of 29" each. For each leg piece, find the best looking face. Label these individually as: front right, front left, back right, or back left.

**B1**



The legs feature many cutouts that make for clean and strong joinery. These cutouts can be made by using a variety of different tools and methods. We'll use a dado blade installed on a table saw (it's the most efficient way).

**B2**



It is possible – though more time consuming – to use a standard table saw blade.

**B3**



You can also use a sliding miter saw with the blade depth locked. With any method, be sure to clear out any chips in the cutout with a chisel to ensure a good joint can be made.

**B4**



If you use a table saw, we recommend using a miter gauge to safely hold the piece while cross cutting.

### C1

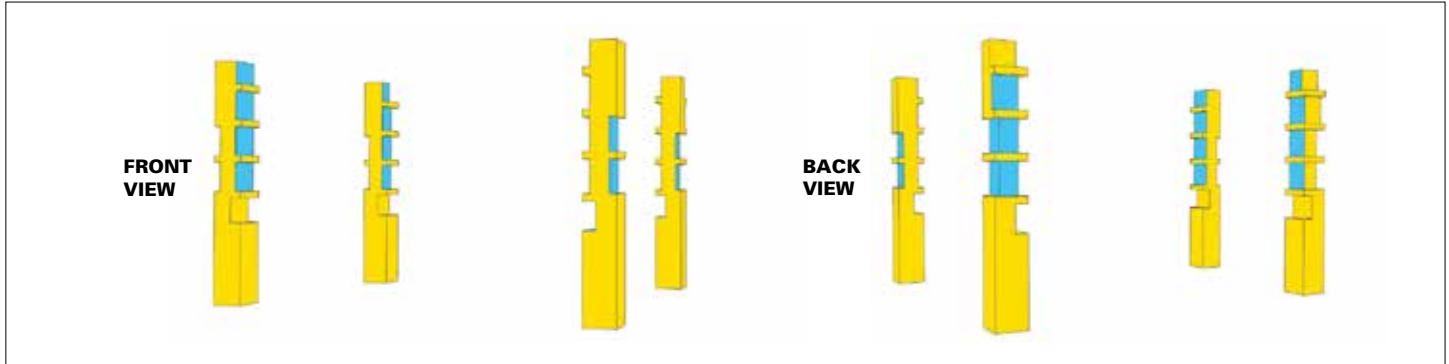

The first cutouts are made to fit the 1x4 stock. Use the diagram drawings on pages 4–7 for measurements.

### C2



Cut a scrap piece of 1x4 to act as a depth and joint-fitting gauge.

### C3



Use a scrap piece of 4x4 to dial in the correct cutting depth.

### C4



Slowly adjust the height of the dado blade until you have an accurate fit with the 1x4 gauge.

### C5



Once the saw is at the correct depth, refer to the diagram drawings and mark your legs for the 1x4 deep cutouts. Begin making the cutouts.

### C6



When you near the completion of a cutout, use your 1x4 scrap to test for a good fit.

### C7



With the cutouts that wrap around the leg, use the cut made on one side to guide your next cuts. By 'wrapping' your cut sequence around the leg, you can avoid misaligned notches.

### C8



As you finish the 3/4" cutouts, test each gap for fit because this will be difficult to modify later.

### D1

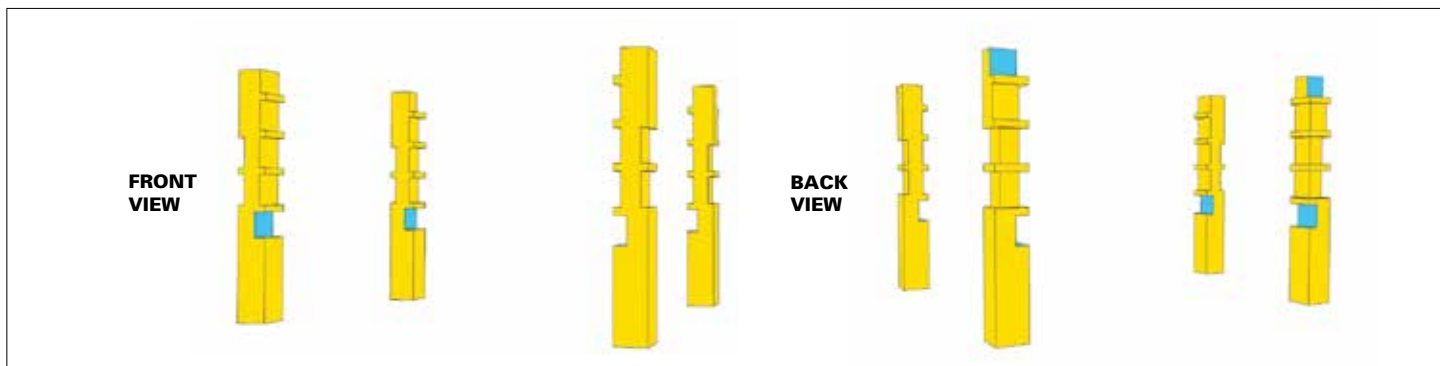

Now move on to the final cutouts. These will be made to fit a 2x4. Use the diagram drawings on pages 4–7 for measurements.

### D2



Slowly adjust the blade to the correct depth.

### D3



Use a scrap piece of 2x4 as a gauge to test the depth. Once the saw is at the correct depth, refer to the diagram drawings and mark your legs for the 2x4 deep cutouts.

### D4



Make the 2x4 cutouts slowly to ensure a clean finish. Be sure to test the fit with the 2x4 gauge before moving on.

## STEP 2: PLATFORM

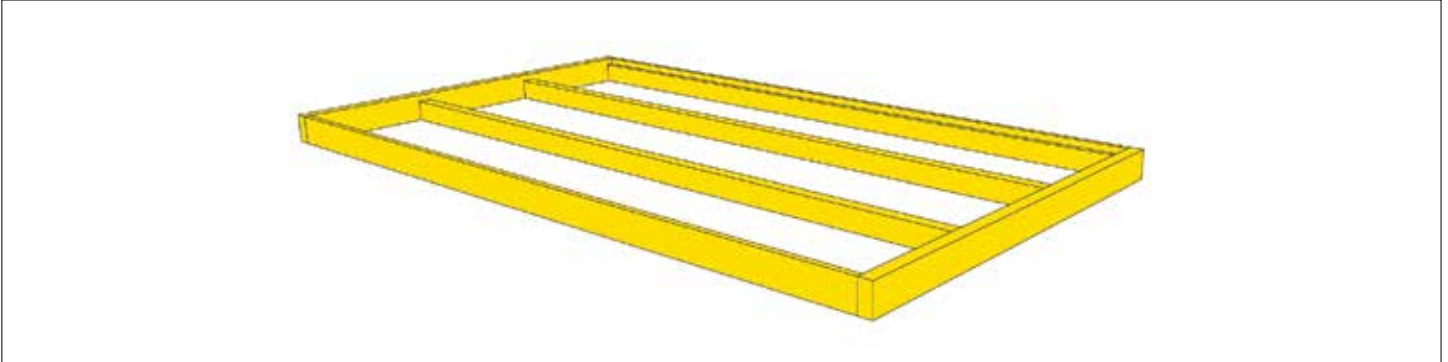

Construct the main platform by cutting and assembling the frame. Refer to the diagram on page 8 for measurements.

### A1



Rip the 2x4s on both sides to eliminate curved edges. We will need fresh square edges for the joinery to fit well. See widths on page 8.

### A2



The front and rear beams for the platform frame are notched to allow the decking to sit flush. Make these cuts on the table saw with both your fence and blade set to 3/4".

### B1



Use 3" galvanized deck screws and glue as fasteners for the assembly of the platform frame. Always pre-drill with a countersink bit to a depth just below the wood surface when using screws.

### B2



Begin assembling the frame. Be sure the joints are all 90 degrees. Use a clamp if necessary.

### B3



Countersink, glue, and screw the frame pieces together. Wipe any excess glue from closed joints with a damp cloth. Make sure outside edges are flush when assembling the front and rear rails.

### B4



The middle beams should be mounted flush to the bottom of the side 2x4s. Note dimensions on page 8.

**C1**

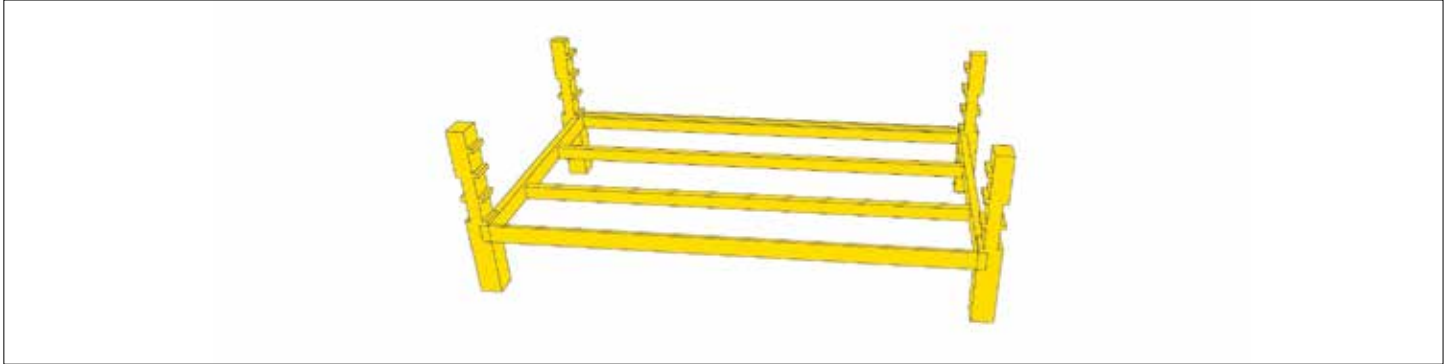

Once the frame assembly is completed, you can move on to attaching the legs.

**C2**



Fit the legs to the assembled platform frame.

**C3**



Countersink, glue, and attach the legs from the inside of the platform frame with 3" screws. Use four screws per joint when attaching the platform to the legs. Make sure the platform frame is flush with the leg surface.

**D1**

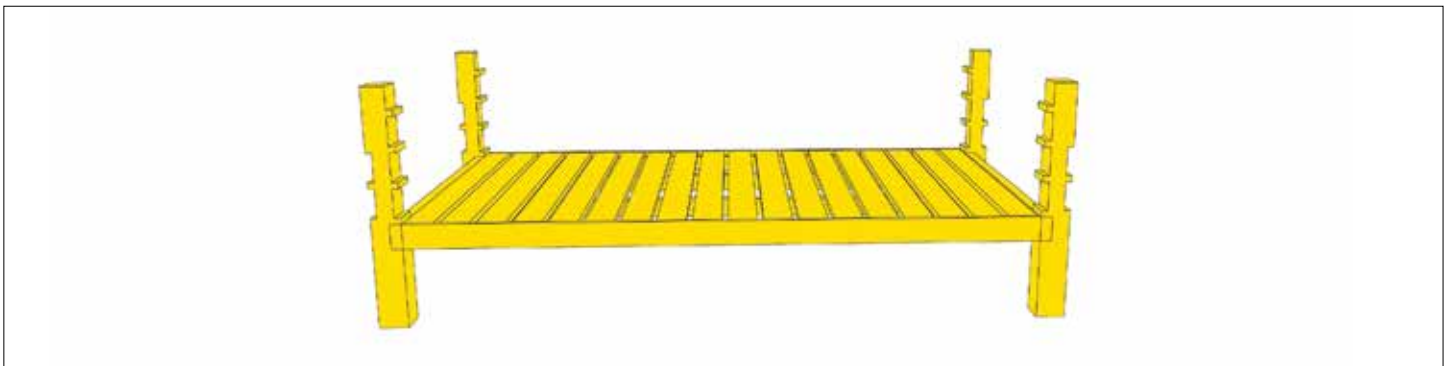

Now move on to installing the decking on the main platform. Refer to the diagram on page 9 for measurements.



### D2



Crosscut 1x4s for the decking. Use the diagram on page 9 for measurements, but test to make sure the decking planks have about 1/8" of wiggle room.

### D3



Lay the planks in the platform frame and install with 1-5/8" screws.

### D4



Use your scrap piece of 1x4 as a jig to set the 3/4" spacing between the planks as you attach.

### D5



The final plank will need to be rip-cut to maintain proper spacing. Measure and cut on the table saw.

## STEP 3: SIDES

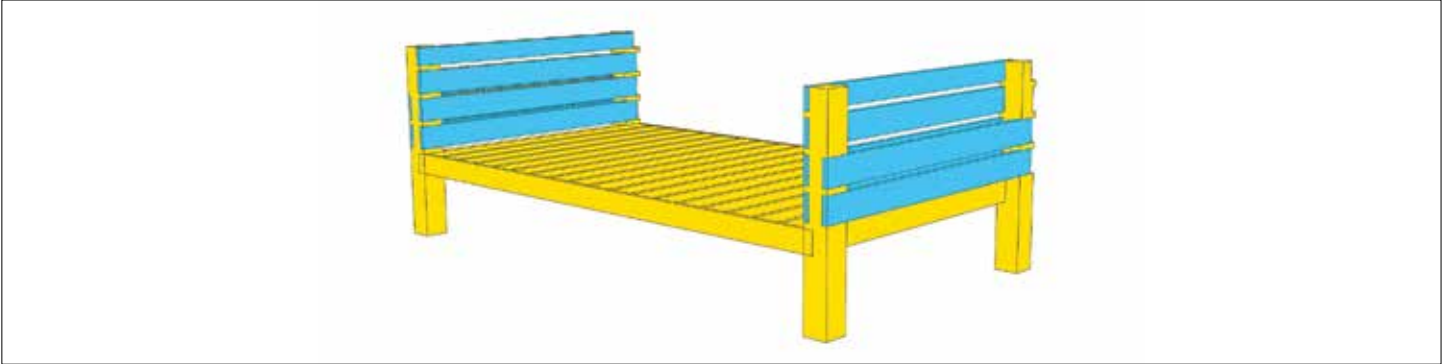

Now install the planks on the sides of the daybed. To ensure a square fit, first install the top planks for maximum leverage. Refer to the diagram on page 10 for measurements.

### A1



Get an accurate measurement for the top side plank. First, measure the overall base of the platform.

### A2



Then subtract the depth measurement of the 2x4 cutout at the back & top of the sides. After cross cutting, you will also need to rip these top planks on the table saw. Refer to the diagram on page 10 for measurements.

### A3



Clamp both sides of the top plank flush with the sides and attach.

### A4



Measure the length needed for the remaining inside planks. Cut and attach the second and third 1x4 planks to each side. Wait on attaching the fourth plank.

### A5



Your project should now look like this.

### B1

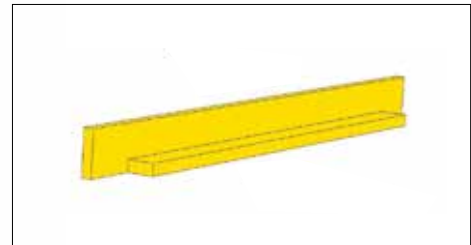

Cut and attach the shelf bottom to the fourth plank before attaching (see steps B2–B5).

**B2**



The shelf bottom is cut from 1x4 stock. Refer to Diagram C on page 10 for measurements.

**B3**



Clamp the bottom piece to the plank and attach with a series of 1-5/8" screws.

**B4**



Fit the completed assembly into place. Use a mallet if needed to ensure a flush fit.

**B5**



Attach the assembly to the legs.

**C1**



Finish the sides by attaching the outside bottom planks to the legs.

**C2**



Countersink and attach the outside bottom plank to the shelf bottom with four evenly spaced screws.

## STEP 4: BACK & TOP

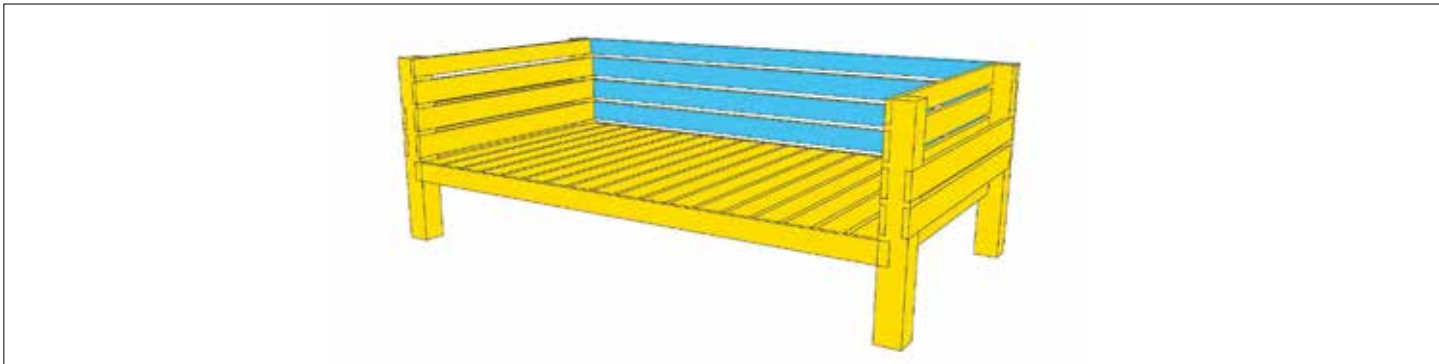

Now move to the back of the daybed. You'll install the four planks top-down. Refer to the diagram on page 11.

### A1



Measure the overall length of the daybed at the level of the platform. Use this measurement for the cut length of all four back planks.

### A2



Attach the top 2x4 plank first. Clamp the plank flush to the leg on both sides and attach with 3" screws.

### B



Cut the three remaining 1x4 back planks, then attach them to the legs with 1-5/8" screws.

### C1



The final assembly step is to attach the tops of the sides and back. Refer to the diagram on page 11.

# Daybed

## BUILDING: BACK & TOP

**C2**



Start with the tops of the sides. Take a separate measurement of each side length.

**C3**



Cut the two top pieces and clamp them to the inner side plank.

**C4**



Attach the top plank with a series of six evenly spaced screws to make a tight seam on the inside.

**D1**



Measure the length of the back for the last top plank.

**D2**



Cut the final top piece from 1x4 stock and trim to fit.

**D3**



Attach the top piece with eight evenly spaced screws.

**D4**



Congratulations! You're done with the daybed construction.

## STEP 5: FINISHING



### A1



Sand all joint faces flush.

### A2



Ease all edges with sandpaper and finish with spray-on or wipe-on weatherproof sealant of your choice.

### A3



Complete the look of your daybed with a covered twin mattress and durable pillows. For full exposure, use exterior-grade textiles. For partial exposure, coat fabric with Scotch-Guard.

### A4



We recommend long lasting YellaWood Protector® semi-transparent stain and water repellent wood sealer, the only stain backed by the famous Yella Tag. Follow manufacturer's recommendations for application.

### FOR INTERIOR OR EXTERIOR APPLICATIONS

Use fasteners and hardware that are in compliance with the manufacturer's recommendations and the building codes for their intended use. As with any good design and construction practices, treated wood should not be used in applications where trapped moisture or water can occur. Where design and/or actual conditions allow for constant, repetitive or long periods of wet conditions, only stainless steel fasteners should be used.

### FOR EXTERIOR APPLICATIONS

The following minimum galvanization levels may be used for connectors, joist hangers, fasteners and other hardware that are placed in direct contact with exterior applications of micronized copper treated wood:

- **Fasteners** - nails, screws, etc.                      ASTM – A 153 (1 oz/ft<sup>2</sup>)
- **Hardware** - connectors, joist hangers, etc.        ASTM – A 653 G90 (0.90 oz/ft<sup>2</sup>)

The effects of other building materials within a given assembly, along with environmental factors, should also be considered when selecting the appropriate hardware and fasteners to use for a given project containing treated wood.

Stainless Steel fasteners and hardware are required for Permanent Wood Foundations below grade and are recommended for use with treated wood in other severe exterior applications such as swimming pools, salt water exposure, etc. Type 304 and 316 are recommended grades to use.

### ALUMINUM

Aluminum building products may be placed in direct contact with YellaWood® brand products used for interior uses and above ground exterior applications such as decks, fencing, and landscaping projects. Examples of aluminum products include siding, roofing, gutters, door and window trim, flashing, nails, fasteners and other hardware connectors. However, direct contact of treated products and aluminum building products should be limited to code-compliant construction applications that provide proper water drainage and do not allow the wood to be exposed to standing water or water immersion.

We recommend you contact the aluminum building products manufacturer for its recommendations regarding use of its aluminum products in contact with treated wood in ground contact applications or when exposed to salt water, brackish water, or chlorinated water, such as swimming pools or hot tubs.

Also check with the aluminum building products manufacturer regarding compatibility with other chemicals and cleaning agents and the use of their aluminum products in commercial, industrial, and specialty applications such as boat construction.

YellaWood® brand pressure treated products are treated with preservatives (the "Preservatives") and preservative methods and technologies of unrelated third parties. For details regarding the Preservatives, methods, and technologies used by Great Southern Wood Preserving, Incorporated, see [www.yellowood.com/preservative](http://www.yellowood.com/preservative) or write us at P.O. Box 610, Abbeville, AL 36310. Ask dealer for warranty details. For warranty or for important handling and other information concerning our products including the appropriate Safety Data Sheet (SDS), please visit us at [www.yellowood.com/warranties](http://www.yellowood.com/warranties) or write us at P.O. Box 610, Abbeville, AL 36310. YellaWood®, YellaWood Protector® and the yellow tag are federally registered trademarks of Great Southern Wood Preserving, Incorporated.

Great Southern Wood Preserving, Incorporated makes no warranties expressed or implied as to the fitness for a particular purpose of this plan.

- Consult the end tag to determine which preservative or preservative system was used in the treatment of that particular product. YellaWood® brand products may be used in direct contact with aluminum building products when limited to code-compliant construction applications that provide proper water drainage and do not allow the wood to be exposed to standing water or water immersion.
- Use fasteners and other hardware that are in compliance with building codes for the intended use.
- Do not burn preserved wood.
- Wear a dust mask and goggles when cutting or sanding wood.
- Wear gloves when working with wood.
- Some preservative may migrate from the treated wood into soil/water or may dislodge from the treated wood surface upon contact with skin.
- Wash exposed skin areas thoroughly.
- All sawdust and construction debris should be cleaned up and disposed of after construction.
- Wash work clothes separately from other household clothing before reuse.
- Preserved wood should not be used where it may come into direct or indirect contact with drinking water, except for uses involving incidental contact such as fresh water docks and bridges.
- Do not use preserved wood under circumstances when the preservative may become a component of food, animal feed or beehives.
- Do not use preserved wood as mulch.
- Only preserved wood that is visibly clean and free of surface residue should be used.
- If the wood is to be used in an interior application and becomes wet during construction, it should be allowed to dry before being covered or enclosed.
- If you desire to apply a paint, stain, clear water repellent or other finish to your preservative-treated wood, we recommend following the manufacturer's instructions and label of the finishing product. Before you start, we recommend you apply the finishing product to a small exposed test area before finishing the entire project to ensure it provides the intended result before proceeding.
- Mold growth can and does occur on the surface of many products, including untreated and treated wood, during prolonged surface exposure to excessive moisture conditions. To remove mold from the treated wood surface, wood should be allowed to dry. Typically, mild soap and water can be used to remove remaining surface mold. For more information visit [www.epa.gov](http://www.epa.gov).
- Projects should be designed and installed in accordance with federal, state and local building codes and ordinances governing construction in your area, and in accordance with the National Design Specifications (NDS) and the Wood Handbook.

### **DISPOSAL RECOMMENDATIONS**

Preserved wood may be disposed of in landfills or burned in commercial or industrial incinerators or boilers in accordance with federal, state and local regulations.



# Daybed // Hack

## PROJECT PLAN

**YellaWood**  
Pressure Treated Pine



## Take your relaxation up a notch with this hack.

The Daybed project provides an ideal lounging zone for any deck or backyard. The addition of the canopy makes this project even better by allowing you to customize the level of shade.

The left and right arm are constructed individually, and then they are attached to the top arms of the Daybed.

The next step involves adding bracing to the arms, and is followed by finishing and protecting the new structure for a long life.

Install some fabric on top and start enjoying your Daybed even more.

### BUILD TIME

**2**  
HRS

### DIFFICULTY



### COST



- Read instructions through and familiarize yourself with the entire process before you begin construction
- Always double check measurements before you make any cuts

- Great Southern Wood cannot be held responsible for incorrect cuts

Get more project plans at [BuildYella.com](https://BuildYella.com)

# Daybed // Hack

OVERALL SIZE

**YellaWood**  
Pressure Treated Pine

TOP

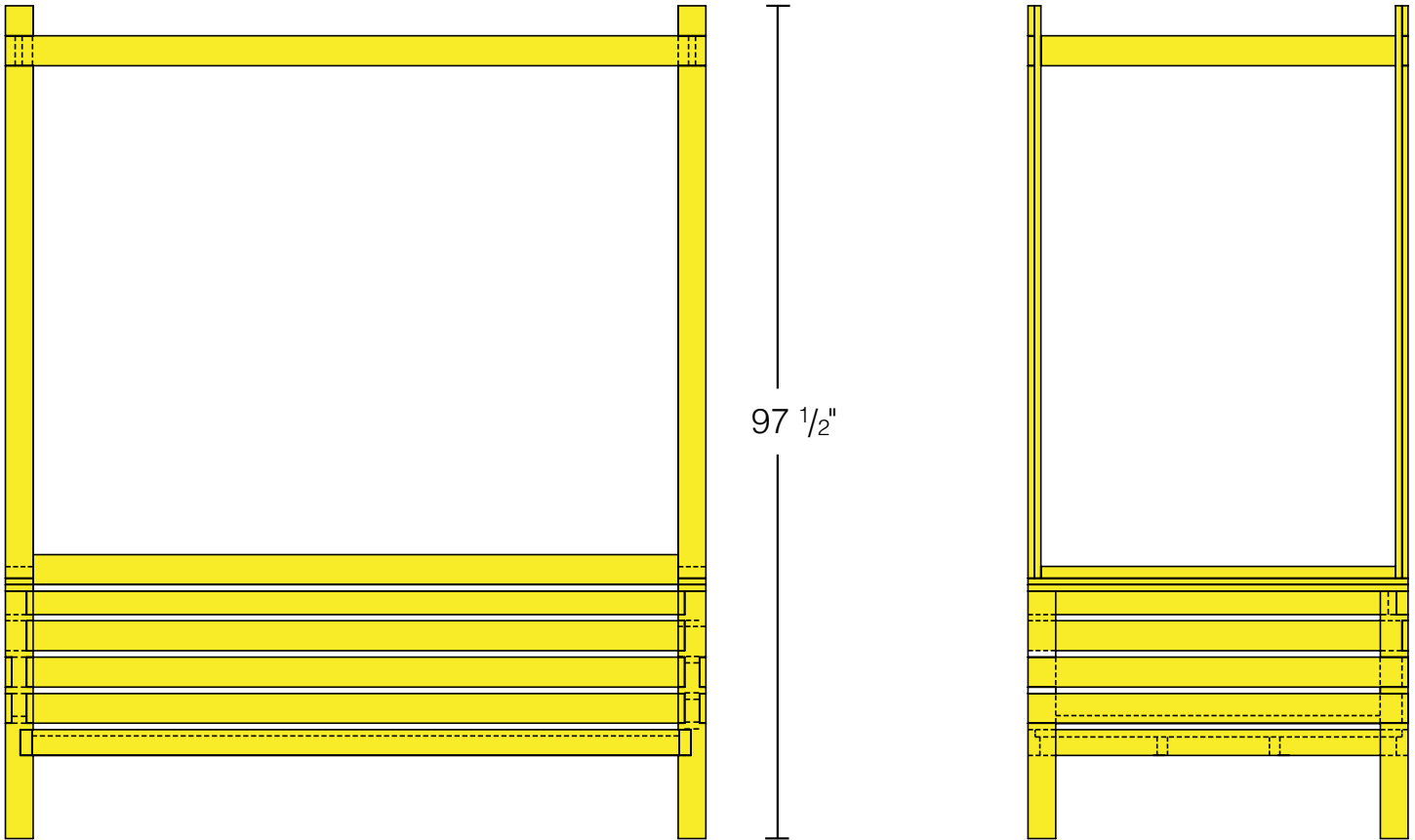

97 1/2"

44 1/2"

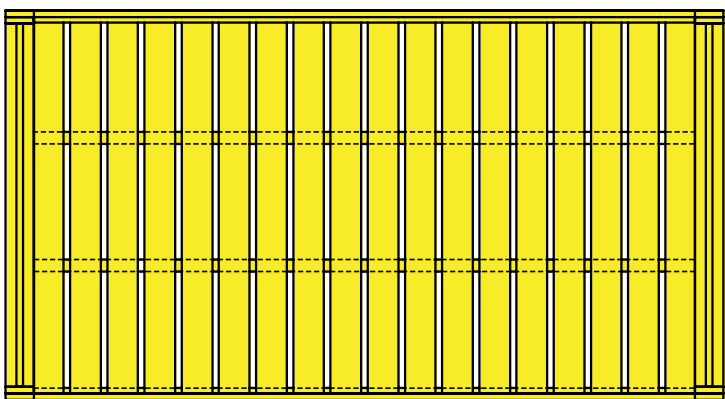

82"

# Daybed // Hack

## OVERVIEW OF STEPS

**YellaWood**  
Pressure Treated Pine

### SEQUENCE OF BUILD

1: TOP ARMS



2: BRACING



3: FINISHING



### BUILD TIME

CUTTING

**1/2**  
HRS

+

ASSEMBLY

**1**  
HRS

+

FINISHING

**1/2**  
HRS

=

TOTAL

**2**  
HRS

IN JUST

**13**  
STEPS

# Daybed // Hack

## WHAT YOU'LL NEED

**YellaWood®**  
Pressure Treated Pine

### MATERIALS

- 2x** 2x4x8' YellaWood® brand pressure treated pine
- 2x** 1x4x10' YellaWood® brand pressure treated pine
- 8x** 1x4x8' YellaWood® brand pressure treated pine

### HARDWARE

#### ½ LB BOX

- 1 5/8" wood screws + appropriate bit
- 2" wood screws + appropriate bit
- 2 1/2" wood screws + appropriate bit

### WOOD FINISHING

- YellaWood Protector® Stain & Sealer

### SAFETY EQUIPMENT

- Work gloves
- Dust mask
- Safety glasses
- Ear protection

### OTHER

- Painter's tape for labeling cut parts

### TOOLS



Pencil



Measuring  
tape



Miter saw  
(or chop saw)



Combination  
countersink bit  
(with 2" long 1/8" bit)



Drill / driver



Radial sander  
(or sanding block)



Damp cloth  
(optional)



Waterproof  
wood glue  
(optional)



Paint/Stain  
Brush

### Notes:

- Consider using YellaWood® KDAT and higher grade products to achieve more professional results.
- Choose boards with minimal irregularity to get the most out of the stock. The following cut list shows efficient nesting of parts per board. If unsure about board quality, purchase 1 extra piece of each board type.

# Daybed // Hack

## CROSS-CUT DIAGRAMS

### PREP: CROSS-CUT ALL PARTS

Proceed to cut all parts listed below unless noted otherwise.  
Be sure to **label all parts** so you know which ones to use for the Assembly Steps that follow.



#### 2x4x8' STOCK 2 BOARDS

CROSSCUT TO	PART	#
41 1/2"	N	2x
75 1/2"	O	1x



#### 1x4x10' STOCK 2 BOARDS

CROSSCUT TO	PART	#
60"	R	4x



#### 1x4x8' STOCK 8 BOARDS

CROSSCUT TO	PART	#
67"	Q	4x
44 1/2"	P	2x
3 1/2"	S	4x
82"	T	2x
41 1/2"	U	2x

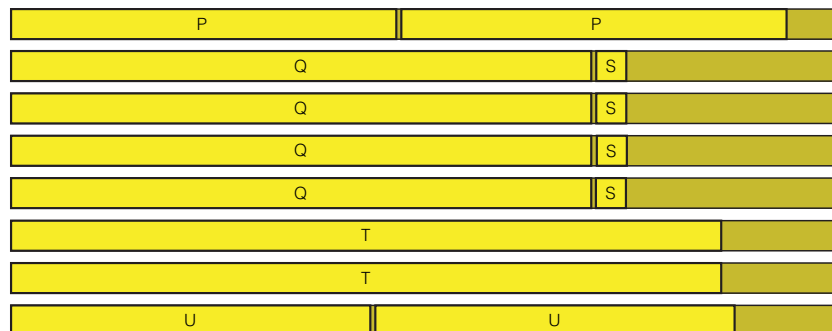

# Daybed // Hack

## IMPORTANT REMINDERS



**AFTER YOU CUT THE PIECES, YOU'RE ALMOST READY TO GO.**

**SEE BELOW FOR IMPORTANT REMINDERS BEFORE GETTING STARTED ON THE ASSEMBLY STEPS.**

- **Read instructions** to familiarize yourself with the entire process before beginning.
- **Always double check measurements** before making cuts—Great Southern Wood is not responsible for incorrect cuts.
- **Pre-drill** holes before attaching screws. Set  $\frac{1}{8}$ " drill bit inside combination counter-sink bit to appropriate depth based on the screw length called for.
- **Wood glue is optional:** if you choose to use it, apply to surfaces before attaching parts, and be sure to wipe up excess with a damp cloth.
- **Check BuildYella.com for updates** to plans.

---

The Cut List is based on the following actual dimensions for board stock:

<b>1x6</b>	$\frac{3}{4}$ " x 5 $\frac{1}{2}$ "
<b>1x2</b>	$\frac{3}{4}$ " x 1 $\frac{1}{2}$ "
<b>2x2</b>	1 $\frac{1}{2}$ " x 1 $\frac{1}{2}$ "
<b>2x4</b>	1 $\frac{3}{8}$ " x 3 $\frac{1}{4}$ "
<b>1x4</b>	$\frac{3}{4}$ " x 3 $\frac{1}{2}$ "
<b>1x8</b>	$\frac{3}{4}$ " x 7 $\frac{1}{4}$ "
<b>2x6</b>	1 $\frac{3}{8}$ " x 5 $\frac{1}{4}$ "
<b><math>\frac{5}{4}</math> x6</b>	$\frac{7}{8}$ " x 5 $\frac{1}{4}$ "
<b>2x10</b>	1 $\frac{1}{2}$ " x 9 $\frac{1}{8}$ "
<b>4x4</b>	3 $\frac{1}{4}$ " x 3 $\frac{1}{4}$ "

# Daybed // Hack

## PART CALL-OUTS

**YellaWood**  
Pressure Treated Pine

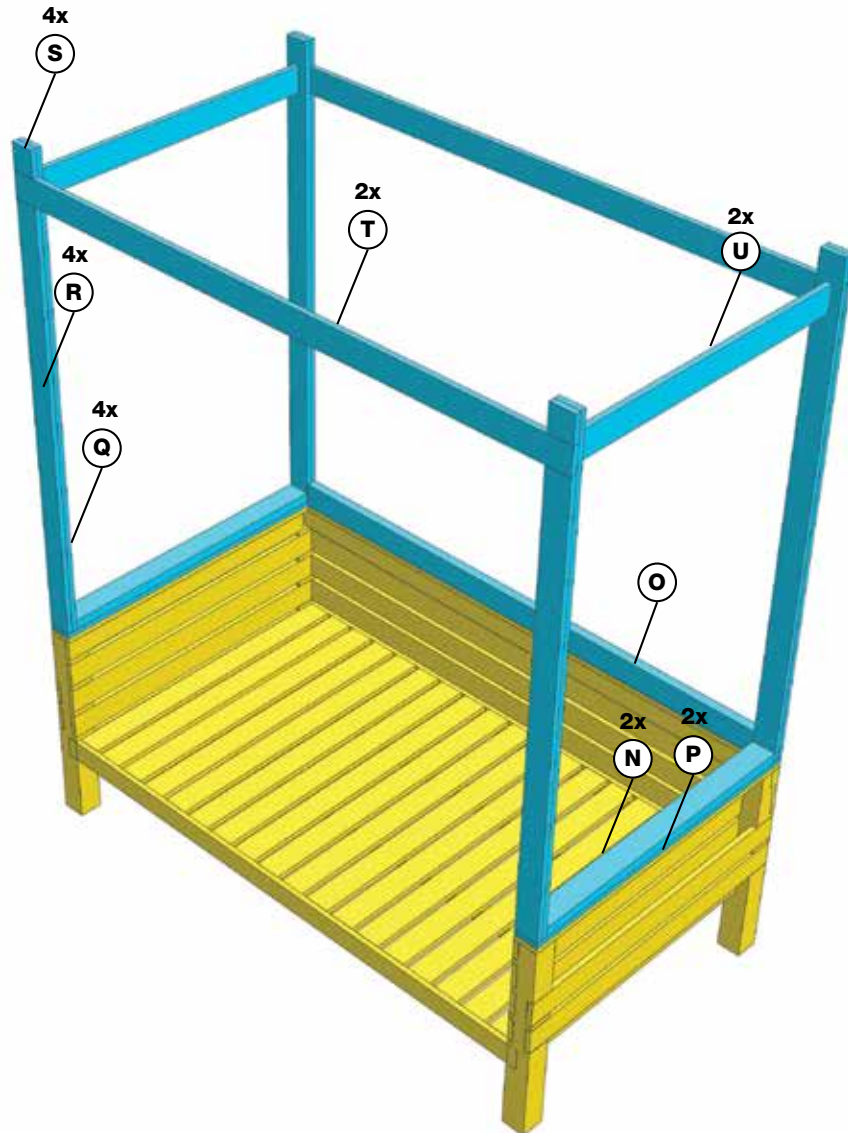

# Daybed // Hack

## ASSEMBLY

**YellaWood**  
Pressure Treated Pine

### INSTRUCTIONS FOR ALL SECTIONS

1



Lay a Part (Q) on a flat surface and place Part (R) directly on top, ensuring the bottom and sides are flush. Attach Part (R) using two 1 5/8" screws on each end and two in the middle.

2



Place Part (S) on top of (Q) with all edges flush. Ensure that the gap formed will fit your 1x4 stock. Then, attach Part (S) with four 1 5/8" screws.

3

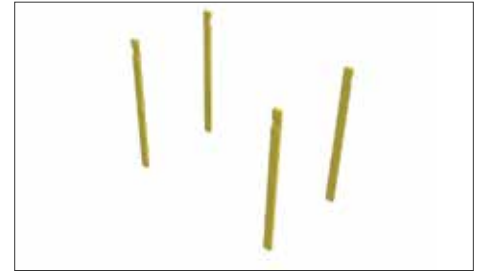

Repeat Steps 1 and 2 until you have four vertical posts.

4



Place Part (N) on top of Part (P) with all edges flush. Center part (N) and check that the spaces on each end will fit two 1x4s on edge. Attach using two 2" screws on each end.

5

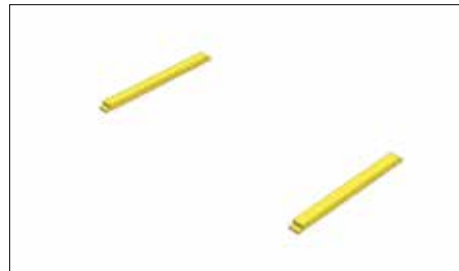

Repeat Step 4 for the other bottom support.

6



Attach two of the vertical posts to part (N) using two 2 1/2" screws on each beam with the cutouts at the top facing away from one another.

7

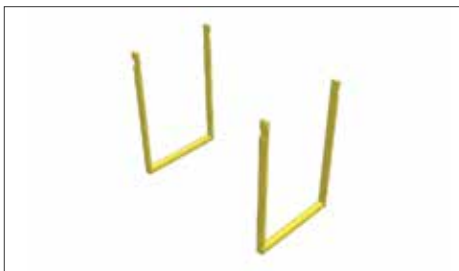

Repeat Step 6 for the other assembly.

8



Place one side assembly on top of one of the Daybed arms. Check that all edges are flush with one another. Attach using five pairs of 2 1/2" screws, spaced evenly down Part (N). Repeat this step on the other side of the Daybed.

9



Attach Part (U) to Parts (Q) as shown. When viewed from the side, Part (U) is aligned with the cutouts in the vertical posts. Part (U) should be centered on Parts (Q). Attach using two 1 5/8" screws on each end.



# Daybed // Hack

## ASSEMBLY

**YellaWood**  
Pressure Treated Pine

### INSTRUCTIONS FOR ALL SECTIONS

10



Take Part (O) and place it on top of the backrest of the Daybed as shown. Attach by toenail-screwing this part in using a 2 1/2" screw on each end.

11



Place a part (T) inside the cutouts of the vertical posts. Check that the edges are flush and attach with four 1 5/8" screws at each joint.

12



Repeat Step 11 on the other side to complete the Daybed Hack.

13



Ease any sharp edges using a radial sander or sanding block with medium grit. Apply preferred finish to the wood.

14



We recommend long lasting YellaWood Protector® semi-transparent stain and water repellent wood sealer, the only stain backed by the famous Yella Tag. Follow manufacturer's recommendations for application.

**CONGRATULATIONS. ENJOY YOUR NEW UPGRADED DAYBED!**

# Daybed // Hack

GALLERY OF IMAGES

**YellaWood**  
Pressure Treated Pine

